

Product Description

ATEK876N4 is a wideband analog tunable band pass filter covering 16.7 to 36.7 GHz frequency range with low in band loss and high rejection.

Filter developed in highly repeatable MMIC manufacturing process, which results in minimal part to part variation.

Filter housed in compact 4x4 mm low cost SMD package, input and output matched to 50 ohms internally.

Evaluation Board, bare die, custom package, and module options are available upon request.

Product Features

- Frequency Range: 16.7 - 36.7 GHz
- Insertion Loss: 11 dB
- Single Supply
- 4x4 mm compact size

Applications

- Wideband Receivers
- Telecommunication
- Test and Measurement
- SATCOM
- SDR

Functional Block Diagram

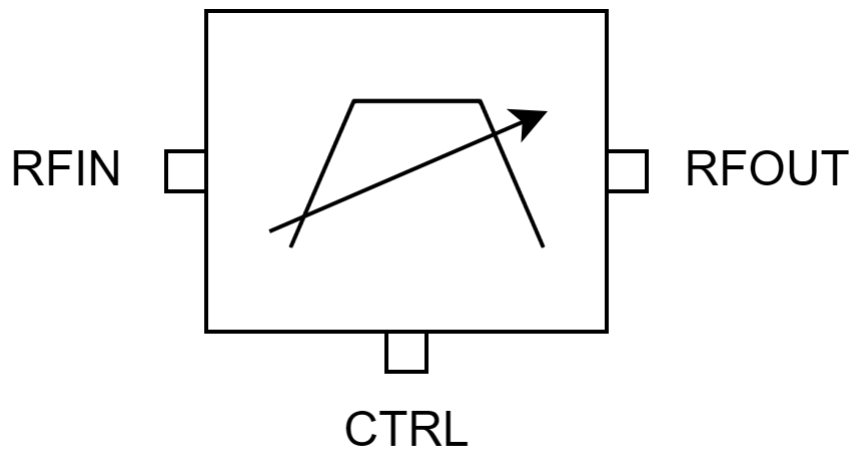

Electrical Specifications

Conditions unless otherwise specified: Typical, T = 25 C, CW.

Parameter		Min	Typ	Max	Units
Operational Frequency Range			16.7 - 36.7		GHz
3dB Bandwidth (High Pass 3dB cutoff - Low Pass 3dB cutoff)	Band at 0V		16.7 - 20.1		GHz
	Band at 2V		21.2 - 26.9		
	Band at 8V		27.9 - 36.7		
Insertion Loss	Band at 0V		17		dB
	Band at 2V		11		
	Band at 8V		8		
Input Return Loss			-7		dB
Output Return Loss			-7		dB
Input IP3			TBD		dBm
Input P1dB			TBD		dBm
Switching Speed 50% Vctrl to 90% of RF Output	On		TBD		ns
	Off		TBD		
Control Voltage (Vctrl)		0		8	V
Control Current			0.4		mA
Operating Temperature		-40		85	°C

Typical Performance Plots

Conditions unless otherwise specified: Typical, T = 25 C, CW.

Insertion Loss

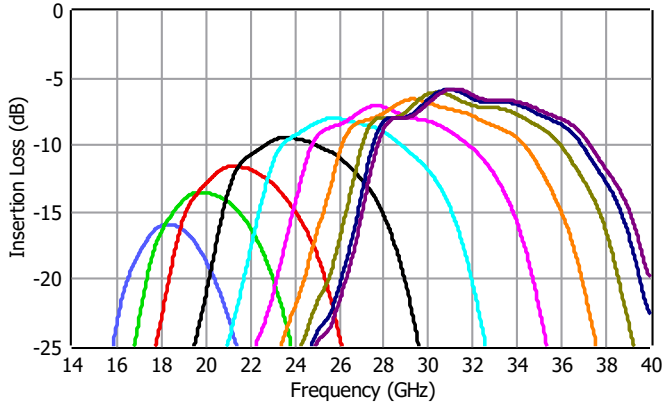

Wideband Insertion Loss

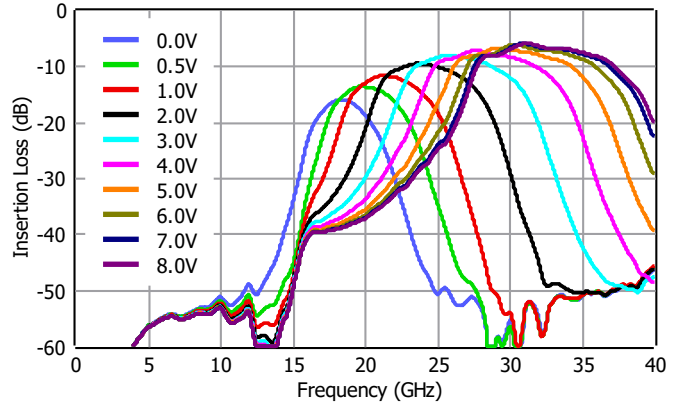

Input Return Loss

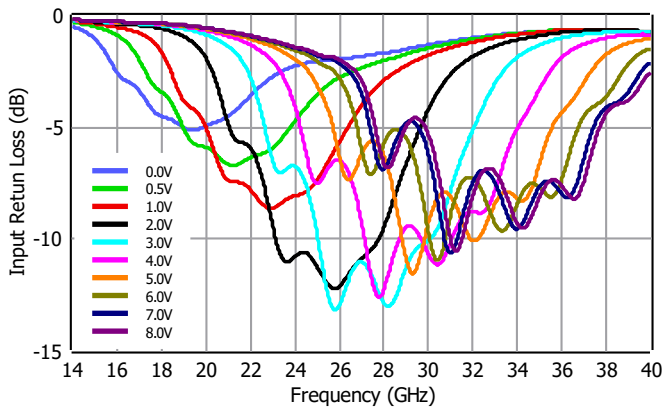

Output Return Loss

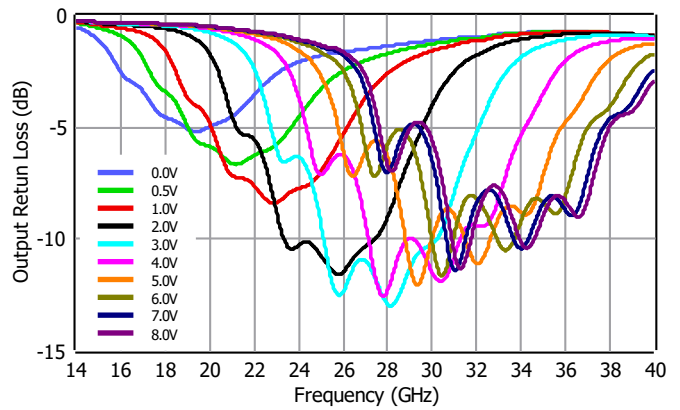

Pin Description

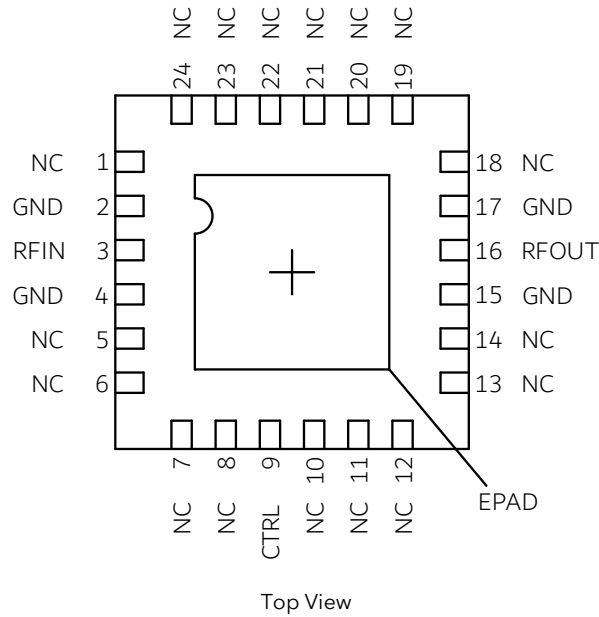

Pin Number	Pin Name	Description
3	RF IN	RF input pin. AC coupled.
16	RF OUT	RF output pin. AC coupled.
9	CTRL	Control Pin.
1, 5-8, 10-14, 18-24	NC	These pins are not internally connected. Can be grounded on the PCB.
2, 4, 15, 17	GND	Ground.
25	EPAD	Exposed Pad on the bottom of the package should be connected to ground with multiple number of vias to reduce the inductance to the GND.

Applications Information

Signal entering from RF IN goes to RF OUT with band pass filtering.
Typical application schematic to operate the filter is given below.

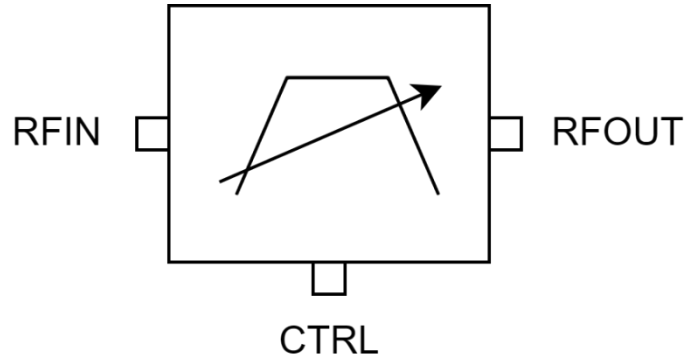

Small signal data are gathered with probe PCB measurements, to generate data shown in this document.

The NC pins of the filter are connected to the GND on the PCBs used to generate the plots shown in this document.

Absolute Maximum Ratings

Parameter	Value/Range
Supply Voltage (Vdd)	TBD
RF Input Power	TBD
Storage Temperature	-55 to +125°C

Operation of this device outside the parameter ranges given above may cause damage. These conditions should not be applied simultaneously.

Mechanical and Marking Information

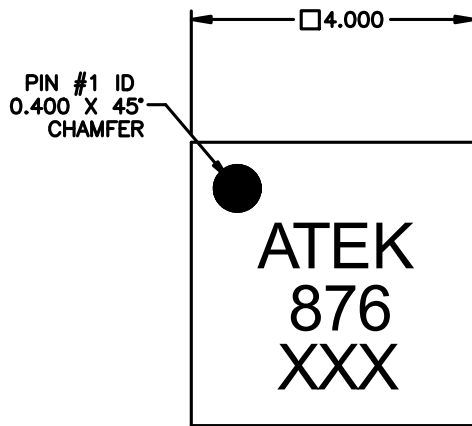

TOP VIEW

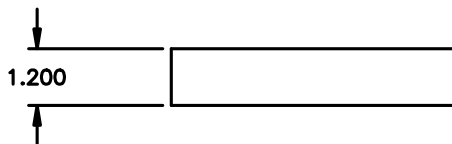

SECTION A-A

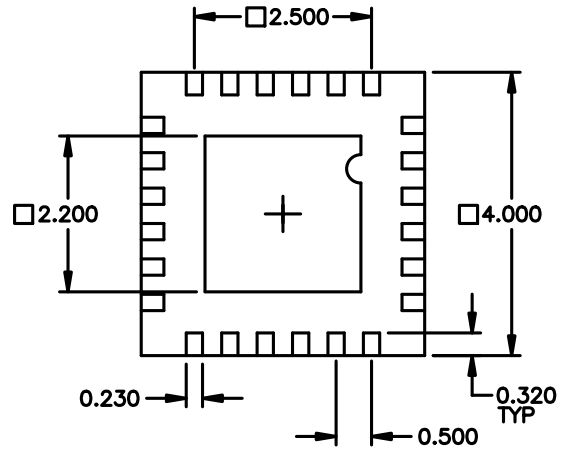

BOTTOM VIEW

NOTES

1. ALL DIMENSIONS IN MM

Handling Precautions



Caution!
ESD-Sensitive Device
Handle Accordingly

Contact Information

For the latest specifications, additional product information, support, and sales.

Web: www.atekmidas.com

Tel: +90-212-483-71-67

Email: support@atekmidas.com

Notice

This document and its contents are property of ATEK MIDAS. ATEK MIDAS has the right to change the document at any time without notice. ATEK MIDAS distributes this document as a service to its customers. ATEK MIDAS supports its customers to help them create market leader products. Customer is responsible from choosing the product and the configuration the product. This document is provided `as is` and does not provide any warranty.

Customer is responsible for the usage of this document, the information provided in the document and the usage of products. ATEK MIDAS shall have no responsibility from the customer products, customer applications and doings of customers.

Revisions

Revision No	Revision Date	Revision Reason	Section / Page No
1.0	26.03.2025	Initial Release	