

Product Description

ATEK766P3 is a wideband frequency mixer covering 6 to 18 GHz RF/LO and LF to 8 GHz IF frequency range. Mixer can be used for both upconversion and downconversion applications.

ATEK766P3 provides low loss over wideband. This allows users to easily realize wideband receiver frontends.

Mixer is housed in a compact 3x3 mm low cost SMD package, input and output are matched to 50 ohms internally.

Evaluation Board, bare die, custom package, and module options are available upon request.

Product Features

- Frequency Range: 6 - 18 GHz
- High IF Bandwidth: 8 GHz
- Conversion Loss: 7 dB
- IIP3: 16 dBm
- IP1dB: 7 dBm
- 3x3 mm compact size

Applications

- Wideband Receivers
- Telecommunication
- Test and Measurement
- SATCOM
- SDR

Functional Block Diagram

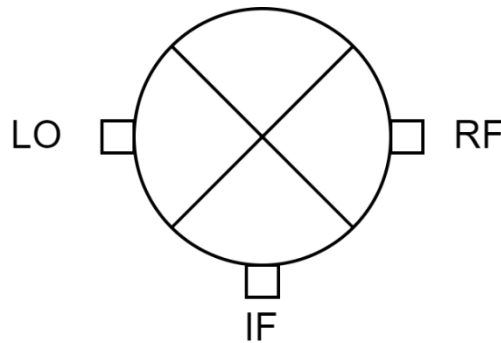

Electrical Specifications

Conditions unless otherwise specified: Typical, T = 25 C, CW.

Parameter		Min	Typ	Max	Units
Operational Frequency Range	RF	6		18	dB
	LO	6		18	
	IF	LF		8.5	
Conversion Loss LO = 13 dBm	1 GHz		7.7		dB
	4 GHz		7.7		
	8 GHz		6.2		
RF Return Loss, LO = 13 dBm at 12 GHz			-10		dB
IF Return Loss, LO = 13 dBm at 12 GHz			-15		dB
LO Return Loss, RF = 13 dBm at 12 GHz			-12		dB
Input IP3			16		dBm
Input P1dB			7		dBm
Operating Temperature		-40		85	°C

Typical Performance Plots

Conditions unless otherwise specified: Typical, T = 25 C, CW.

RF Return Loss vs LO Power at LO = 6 GHz

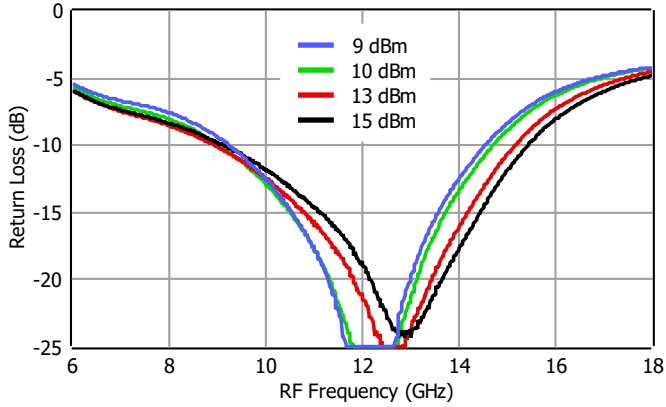

RF Return Loss vs LO Power at LO = 8 GHz

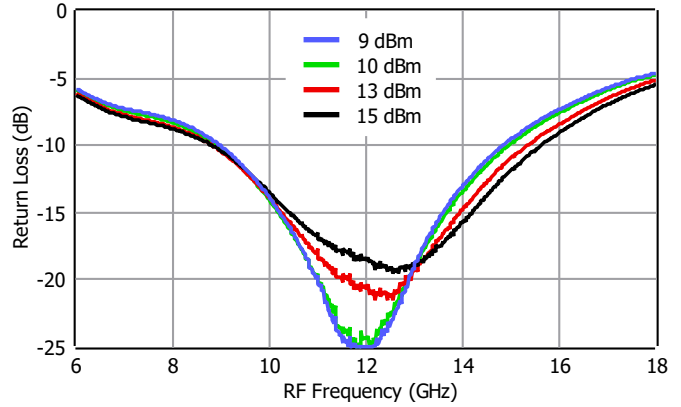

RF Return Loss vs LO Power at LO = 12 GHz

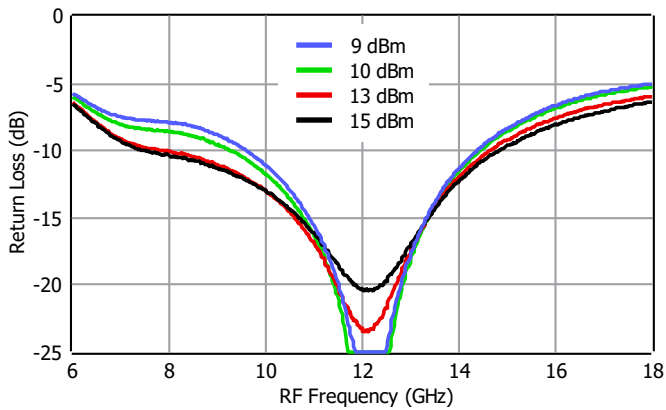

RF Return Loss vs LO Power at LO = 16 GHz

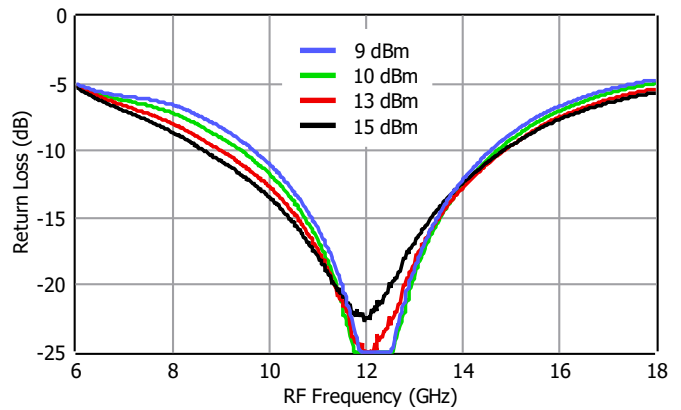

RF Return Loss vs LO Power at LO = 18 GHz

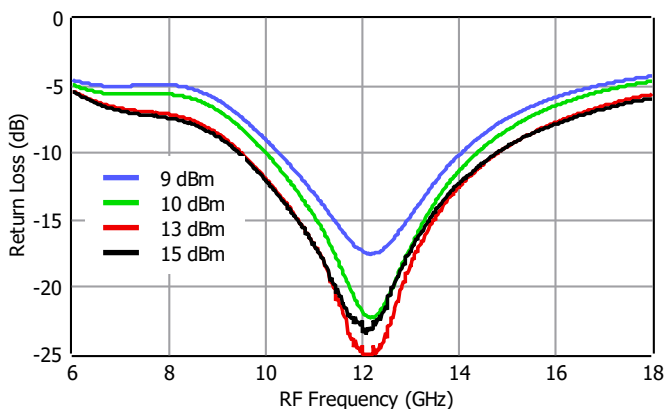

Typical Performance Plots

Conditions unless otherwise specified: Typical, T = 25 C, CW.

IF Return Loss vs LO Power at LO = 6 GHz

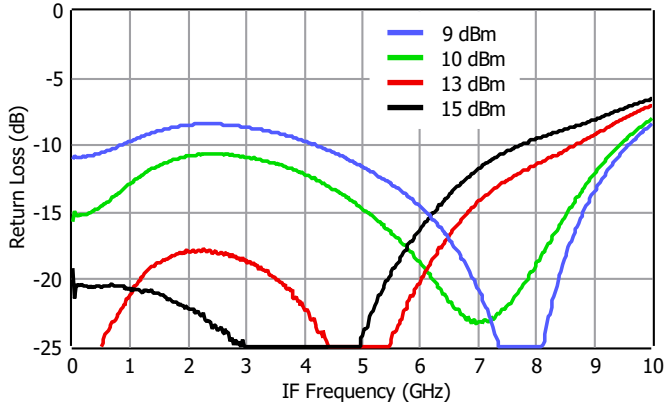

IF Return Loss vs LO Power at LO = 8 GHz

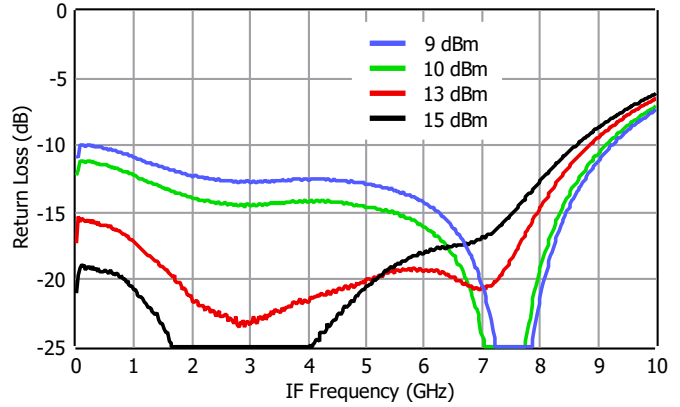

IF Return Loss vs LO Power at LO = 12 GHz

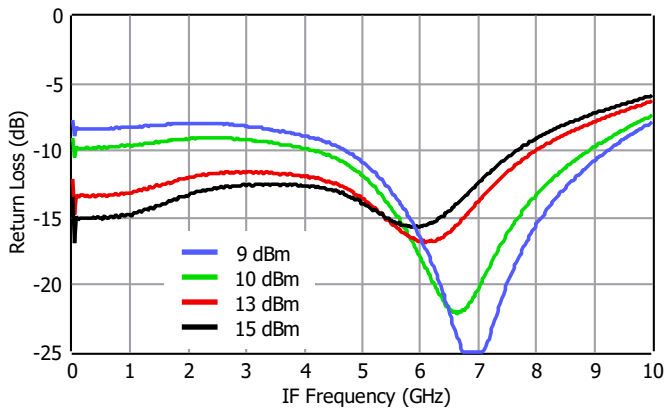

IF Return Loss vs LO Power at LO = 16 GHz

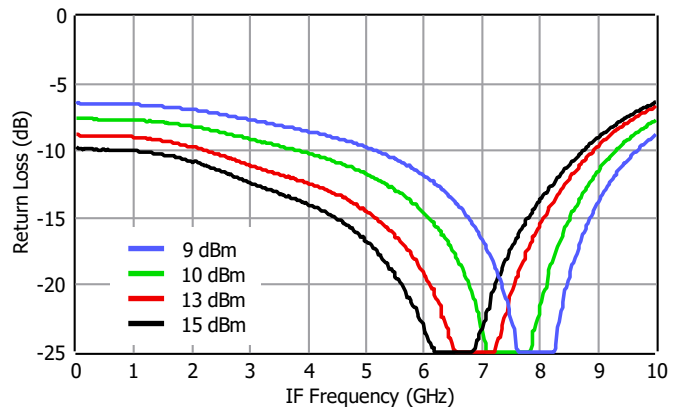

IF Return Loss vs LO Power at LO = 18 GHz

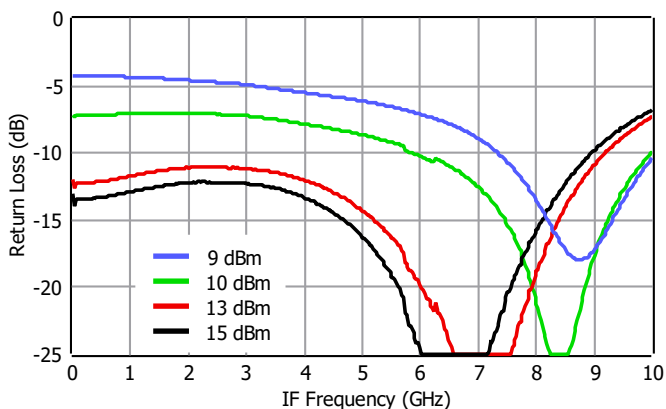

Typical Performance Plots

Conditions unless otherwise specified: Typical, T = 25 C, CW.

LO Return Loss vs RF Power at RF = 6 GHz

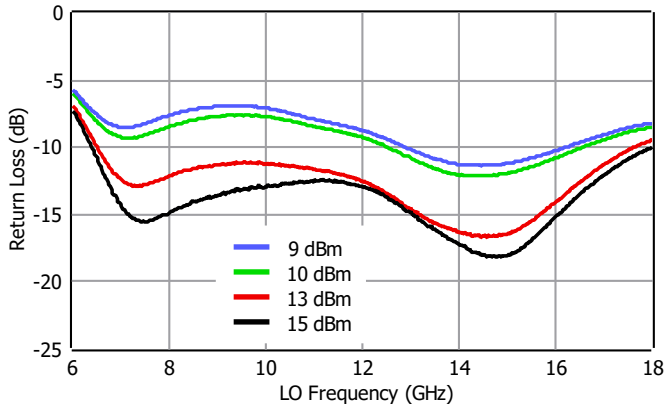

LO Return Loss vs RF Power at RF = 8 GHz

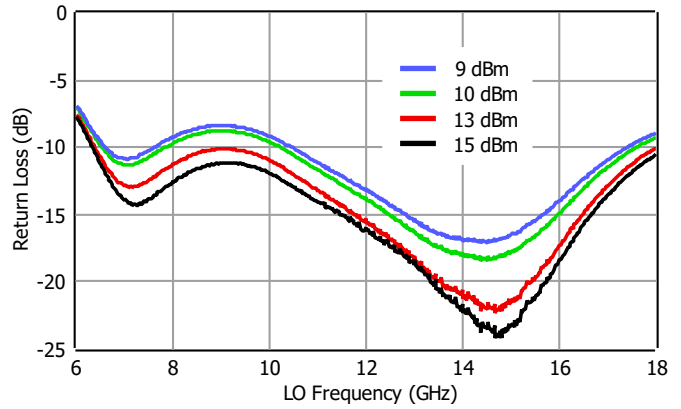

LO Return Loss vs RF Power at RF = 10 GHz

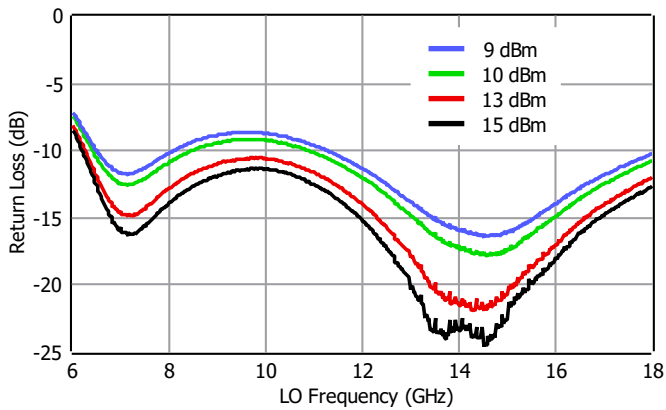

LO Return Loss vs RF Power at RF = 12 GHz

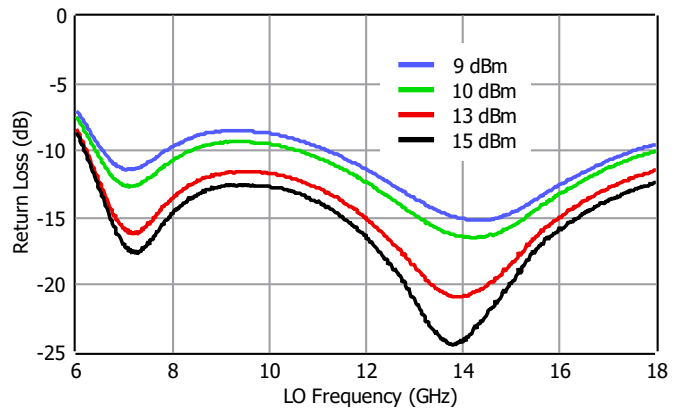

Typical Performance Plots

Conditions unless otherwise specified: Typical, T = 25 C, CW. Upconverter, High Side LO, RF OUT = 9.5 GHz.

Conversion Gain vs IF Frequency

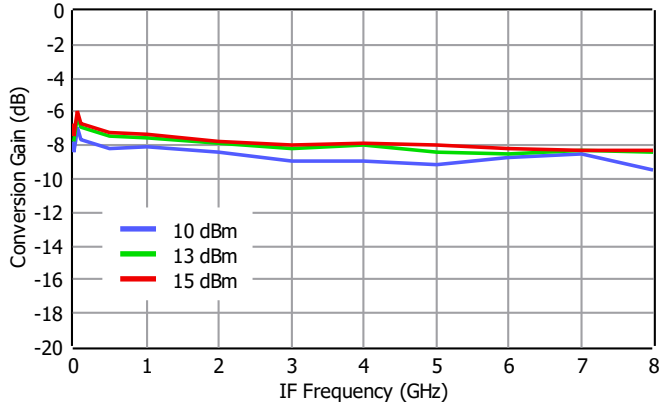

Conversion Gain vs IF Frequency, Low Frequency

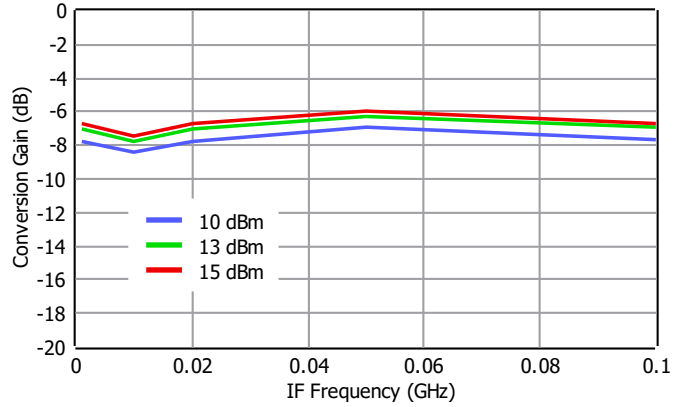

Input IP3 vs IF Frequency

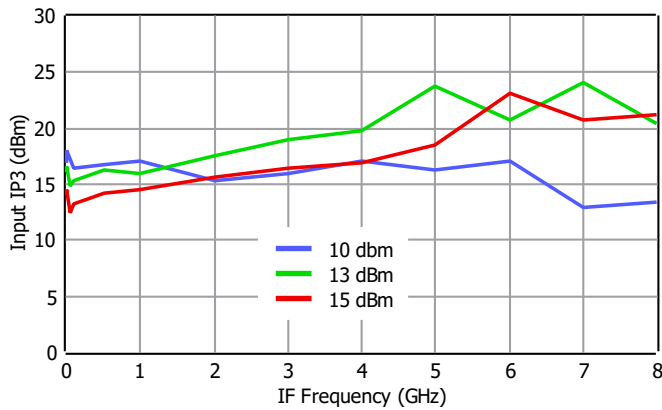

Input IP3 vs IF Frequency, Low Frequency

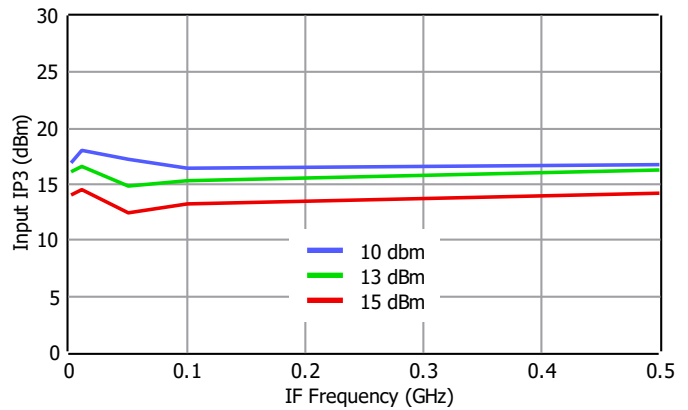

Input P1dB vs IF Frequency

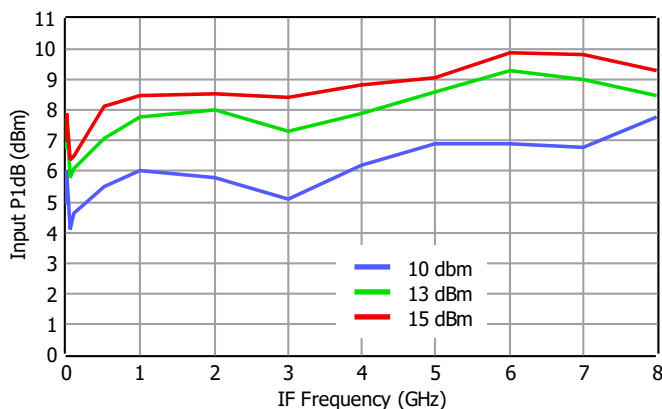

Input P1dB vs IF Frequency, Low Frequency

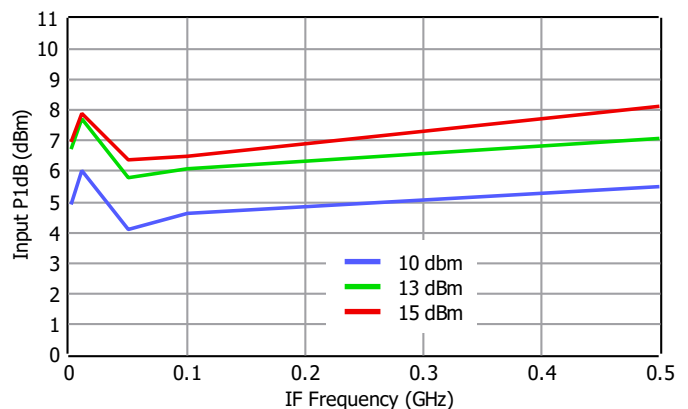

Typical Performance Plots

Conditions unless otherwise specified: Typical, T = 25 C, CW. Downconverter, High Side LO, RF IN = 9.5 GHz.

Conversion Gain vs IF Frequency

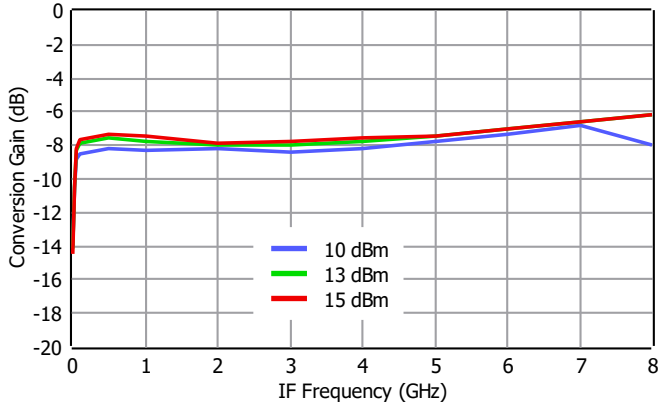

Conversion Gain vs IF Frequency, Low Frequency

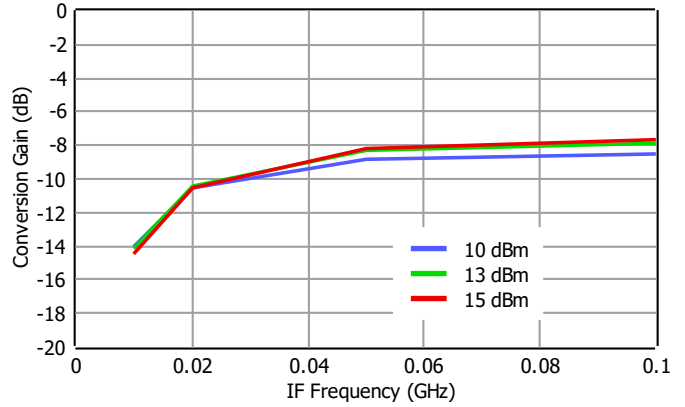

Input IP3 vs IF Frequency

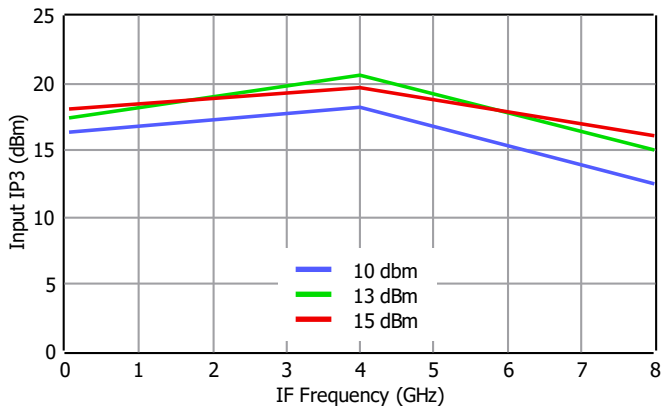

Pin Description

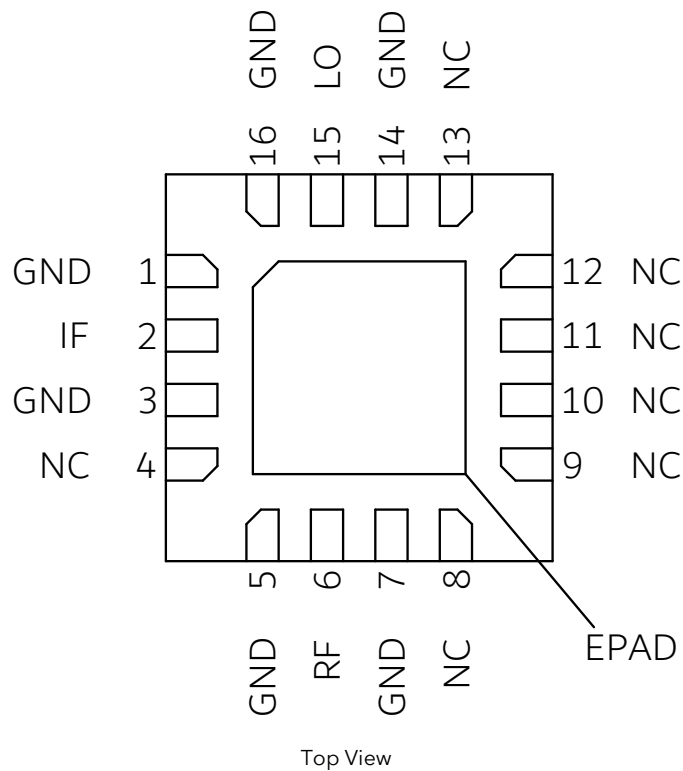

Pin Number	Pin Name	Description
6	RF	RF input/output pin. This pin is AC coupled.
15	LO	LO input/output pin. This pin is AC coupled.
2	IF	RF input/output pin. If the DC voltage level on IF line is not equal to 0 V, an external DC block capacitor is required.
4, 8-13,	NC	These pins are not internally connected. Can be grounded on the PCB.
1, 3, 5, 7, 14, 16	GND	Ground.
17	EPAD	Exposed Pad on the bottom of the package should be connected to ground with multiple number of vias to reduce the inductance to the GND.

Applications Information

Typical application schematic to operate the mixer is given below.

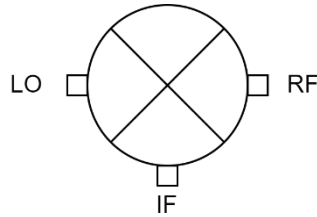

ATEK766P3 mixer can be used for both frequency up conversion and down conversion applications.

For frequency up conversion applications input signal is applied to IF pin, LO signal is applied to LO pin. Frequency upconverted signal goes to RF pin as an output.

For frequency down conversion applications input signal is applied to RF pin, LO signal is applied to LO pin. Frequency down converted signal goes to IF pin as an output. LO and RF ports are interchangeable.

ATEK766P3 can be used as the first mixer of a wideband 10MHz-6/8 GHz receiver as shown below. RF Output frequency can be chosen anywhere at 6-12 GHz.

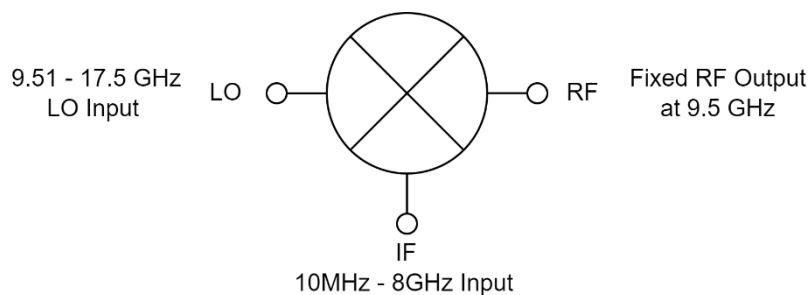

1xLO Leakage and NxIF Spurs at RF OUT.

Upconverter, High Side LO, LO Power = 13 dBm, IF Input = -20 dBm, RF OUT = 9.5 GHz.

IF Frequency (MHz)	LO Frequency (GHz)	1x LO (dBm)	1x IF (dBc)	2x IF (dBc)	3x IF (dBc)	4x IF (dBc)
1	9.501	-19.4	72.6	94.1	94.1	94.1
10	9.51	-19.7	74.5	94.5	94.5	94.5
20	9.52	-20.6	51.9	93.4	93.4	*
50	9.55	-21.2	46.6	94.1	94.1	*
100	9.6	-20.7	39.7	94.9	94.9	*
500	10	-19.8	33	89.2	94.2	*
1000	10.5	-18.5	18.6	83.7	93.7	93.7
2000	11.5	-18.7	13.1	68.1	83.6	83.6
3000	12.5	-20.7	7.4	56.8	83.3	78.3
4000	13.5	-22.3	3.7	52.5	78	73
5000	14.5	-21.5	3.8	43.2	83.2	93.2
6000	15.5	-19.7	2.8	48.8	82.8	92.8
7000	16.5	-16.2	4.6	54.6	82.6	92.6
8000	17.5	-12.4	8.9	51.1	82.9	92.9

*: Equipment noise floor.

Large signal datasheet plots are generated by connectorized evaluation boards (EVBs), PCB and connector losses are de-embedded. Small signal plots are generated by probing the RF lines with RF probes to eliminate the connector transition effects.

The NC pins of the Mixer are connected to the GND on the PCBs used to generate the plots shown in this document.

Absolute Maximum Ratings

Parameter	Value/Range
Supply Voltage (Vdd)	TBD
RF Input Power	TBD
Storage Temperature	-55 to +125°C

Operation of this device outside the parameter ranges given above may cause damage. These conditions should not be applied simultaneously.

Mechanical and Marking Information

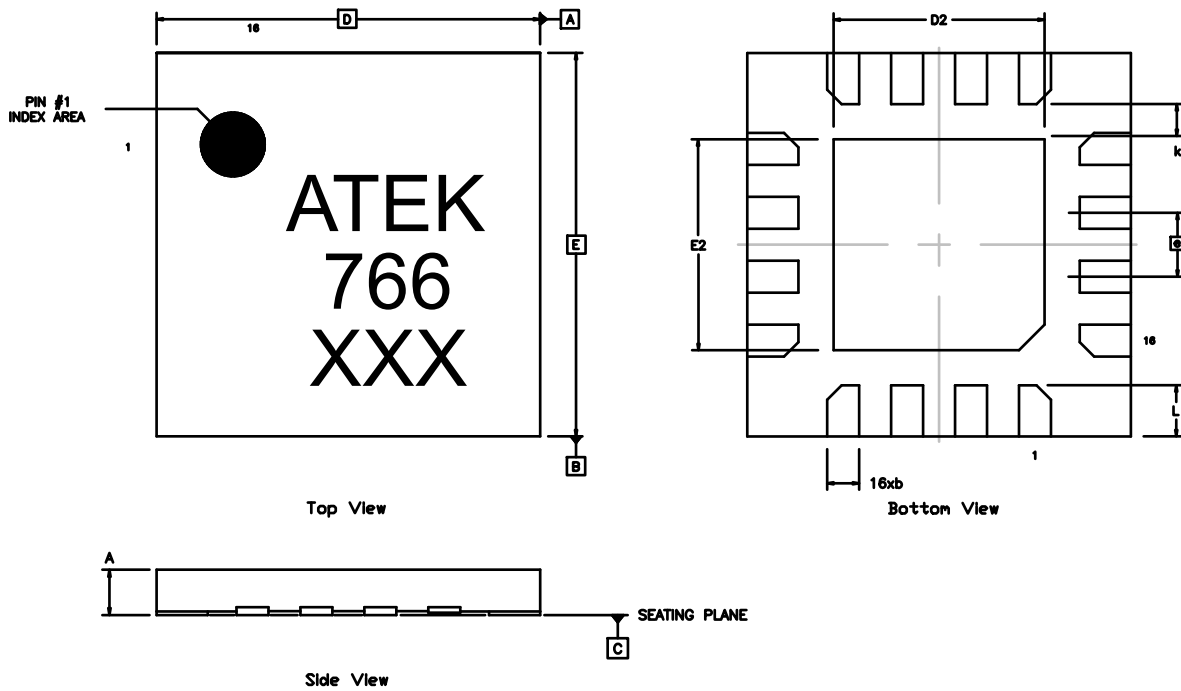

NOTES:
1) ALL DIMENSIONS IN MM

SYMBOL	MIN	MAX	SYMBOL	MIN	MAX
A, V	0.80	1.00	E2	1.55	1.75
b	0.18	0.30	e	0.50	BSC
D	3.00	BSC	k	0.20	-
D2	1.55	1.75	L	0.35	0.45
E	3.00	BSC			

Handling Precautions



Caution!
ESD-Sensitive Device
Handle Accordingly

Contact Information

For the latest specifications, additional product information, support, and sales.

Web: www.atekmidas.com

Tel: +90-212-483-71-67

Email: support@atekmidas.com

Notice

This document and its contents are property of ATEK MIDAS. ATEK MIDAS has the right to change the document at any time without notice. ATEK MIDAS distributes this document as a service to its customers. ATEK MIDAS supports its customers to help them create market leader products. Customer is responsible from choosing the product and the configuration the product. This document is provided `as is` and does not provide any warranty.

Customer is responsible for the usage of this document, the information provided in the document and the usage of products. ATEK MIDAS shall have no responsibility from the customer products, customer applications and doings of customers.

Revisions

Revision No	Revision Date	Revision Reason	Section / Page No
1.0	03.05.2023	Initial Release	
1.1	11.05.2023	Return Loss Plots Revised and Large Signal Data Added	
1.2	18.05.2023	Format and Content Fixed	