

## 2 - 18 GHz Switchable Filter Bank

### Product Description

ATEK656N5 is a sub-octave switchable filter bank covering 2 to 18 GHz. The filterbank consists of an SP6T switch followed by 6 fixed frequency band pass filters which are followed by another SP6T switch.

RF input and output are internally matched to 50 ohms for ease of use. A 3-bit 0/-5V control is used to select the 6 filter bank states.

Housed in a 5x5mm SMD package, the ATEK656N5 filterbank provides +33 dBm IIP3 which allows users to realize high dynamic range wideband receiver frontends. The sub-octave filterbank architecture improves overall system IIP2.

Evaluation Board, custom package and module options are available upon request.

### Product Features

- Frequency Range: 2 to 18 GHz
- 6 Switchable Band Pass Filters
- Rejection: -30 to -40dBc
- Tuning Speed: 120 nS
- Input IP3: +33 dBm
- 5x5 mm compact size

### Applications

- Wideband Receivers, SDRs
- Telecommunication
- Test and Measurement
- SATCOM
- EW / ECM / C-UAS

### Functional Block Diagram

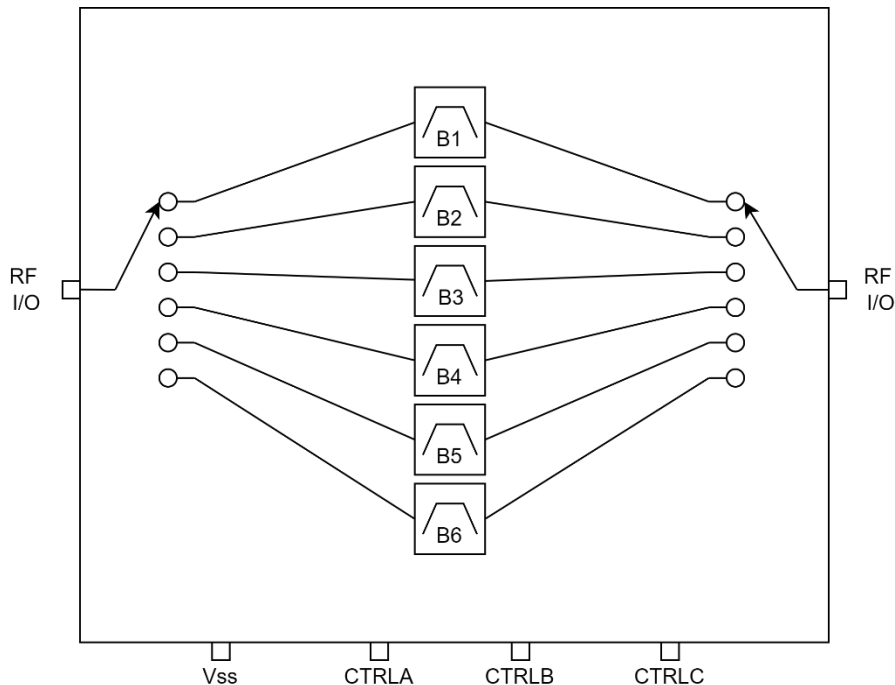

**2 - 18 GHz Switchable Filter Bank**

**Electrical Specifications**

Conditions unless otherwise specified:  $V_{SS} = -5V$ , Typical,  $T = 25\text{ C}$ , CW.

Parameter		Min	Typ	Max	Units
Operational Frequency Range		2		18	GHz
3dB Bandwidth (High Pass 3dB cutoff - Low Pass 3dB cutoff)	Band 1		1.9 - 3.5		GHz
	Band 2		2.8 - 5.4		
	Band 3		4.5 - 9.1		
	Band 4		7.1 - 12.3		
	Band 5		9.9 - 15.3		
	Band 6		12.5 - 18		
Insertion Loss	Band 1		7.5		dB
	Band 2		6.5		
	Band 3		6.5		
	Band 4		7.5		
	Band 5		9		
	Band 6		9		
Input Return Loss			-12		dB
Output Return Loss			-10		dB
Input IP3			33		dBm
Input P1dB			23		dBm
Switching Speed 50% Vctrl to 90% of RF Output	On		120		ns
	Off		25		
DC Supply Voltage ( $V_{SS}$ )			-5		V
DC Supply Current			12		mA
Control Voltage (CTRL)	Low		0		V
	High		-5		
Operating Temperature		-40		85	°C

## 2 - 18 GHz Switchable Filter Bank

### Typical Performance Plots

Conditions unless otherwise specified:  $V_{SS} = -5V$ , Typical,  $T = 25\text{ C}$ , CW.

Insertion Loss

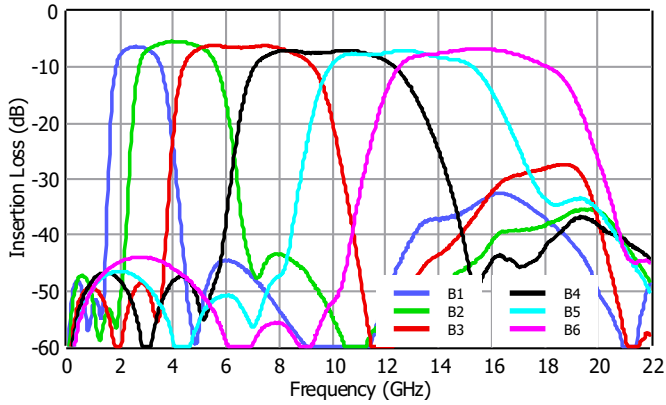

Insertion Loss, Zoom

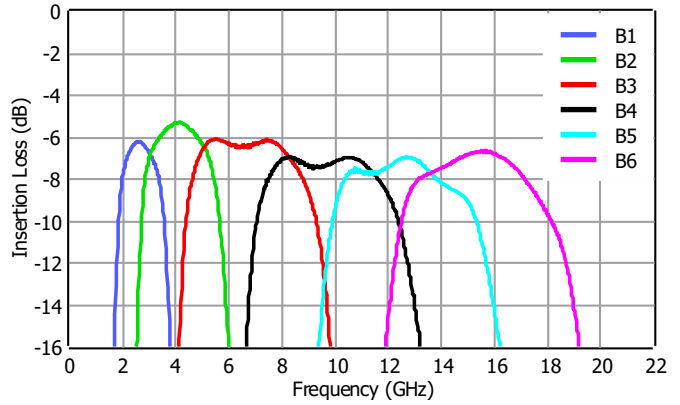

Insertion Loss, Log Scale

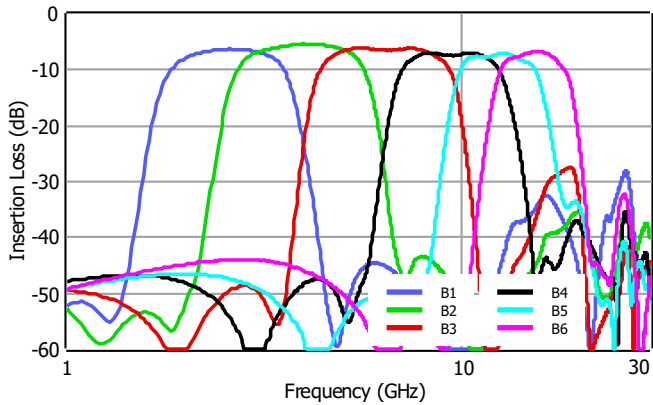

Input Return Loss

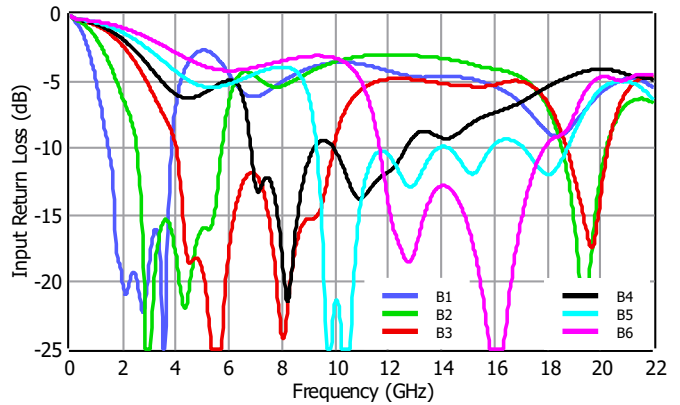

Output Return Loss

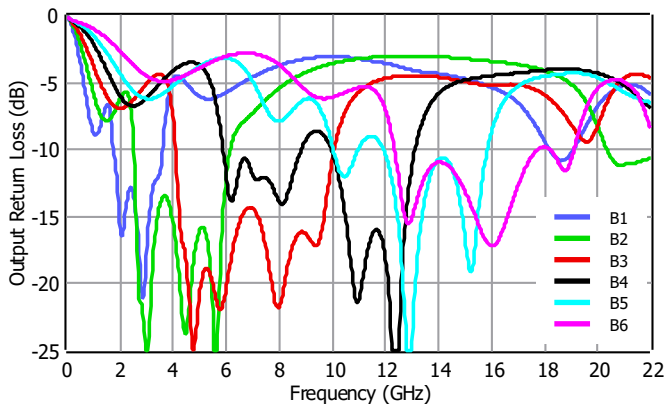

**2 - 18 GHz Switchable Filter Bank**

**Typical Performance Plots**

Conditions unless otherwise specified:  $V_{SS} = -5V$ , Typical,  $T = 25\text{ C}$ , CW.

Input P1dB

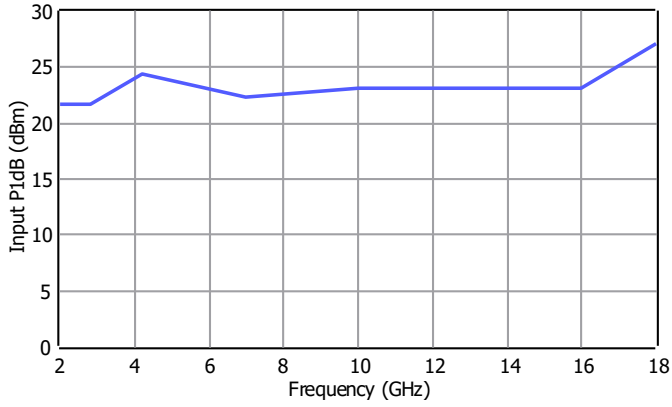

Input IP3

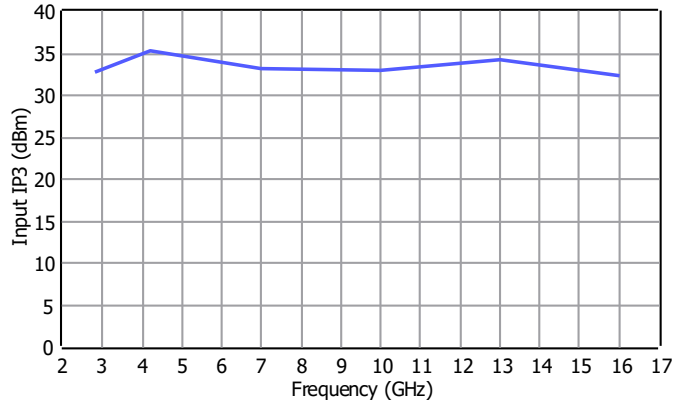

## 2 - 18 GHz Switchable Filter Bank

### Pin Description

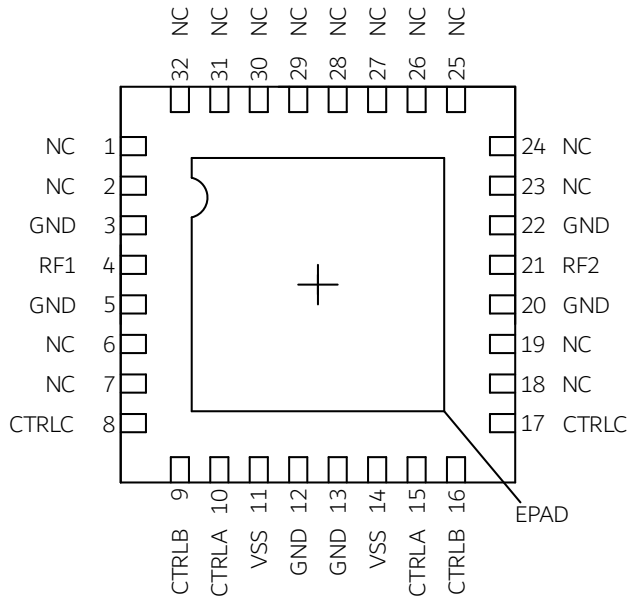

Top View

Pin Number	Pin Name	Description
4	RF1	RF input/output pin. If the DC voltage level on RF lines is not equal to 0 V, an external DC block capacitor is required.
21	RF2	RF input/output pin. If the DC voltage level on RF lines is not equal to 0 V, an external DC block capacitor is required.
11, 14	Vss	Voltage supply pin.
10, 15	CTRLA	Control pin. Two CTRLA pins are shorted internally. Using one of them is sufficient for controlling filter state.
9, 16	CTRLB	Control pin. Two CTRLB pins are shorted internally. Using one of them is sufficient for controlling filter state.
8, 17	CTRLC	Control pin. Two CTRLC pins are shorted internally. Using one of them is sufficient for controlling filter state.
1, 2, 6, 7, 18, 19, 23-32	NC	These pins are not internally connected. Can be grounded on the PCB.
3, 5, 12, 13, 20, 22	GND	Ground.
33	EPAD	Exposed Pad on the bottom of the package should be connected to ground with multiple number of vias to reduce the inductance to the GND.

### Control Interface

CTRLA	CTRLB	CTRLC	Filter Bank State
HIGH	HIGH	HIGH	Band1
LOW	HIGH	LOW	Band2
HIGH	LOW	HIGH	Band3
LOW	LOW	HIGH	Band4
LOW	HIGH	HIGH	Band5
HIGH	HIGH	LOW	Band6

## 2 - 18 GHz Switchable Filter Bank

### Applications Information

Signal entering the RF1 pin goes into 6 selectable paths. All these paths are fixed frequency band pass filters. A typical application schematic to operate the filterbank is given below.

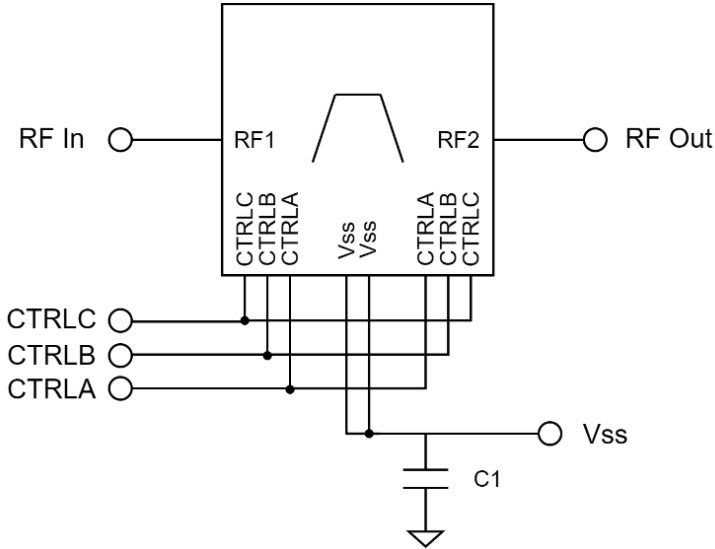

C1 is used to filter out the ripples and unwanted signals coming from the Vss supply. Using additional capacitors in parallel to C1 will improve this filtering. If this filtering is of no concern, then filterbank can be operated without C1.

Filterbank can be supplied in alternative packages and custom housing.

CTRL voltages are used for setting the switch state.

Small signal plots are gathered with probe PCB measurements, to generate data shown in this document, where RF1 is input and RF2 is the output.

Large signal data is generated with the ATEK656N5 mounted to a connectorized evaluation PCB. The PCB trace and connector transition losses are de-embedded, to generate plots shown in this document.

The NC pins of the Filterbank are connected to the GND on the PCBs used to generate the plots shown in this document.

**2 - 18 GHz Switchable Filter Bank**

**Absolute Maximum Ratings**

Parameter	Value/Range
Supply Voltage (Vss)	-6V
RF Input Power (Vss= -5.0V)	+30dBm
Operating Temperature	-40 to +85 °C
Storage Temperature	-55 to +125 °C

Operation of this device outside the parameter ranges given above may cause damage. These conditions should not be applied simultaneously.

**Mechanical and Marking Information**

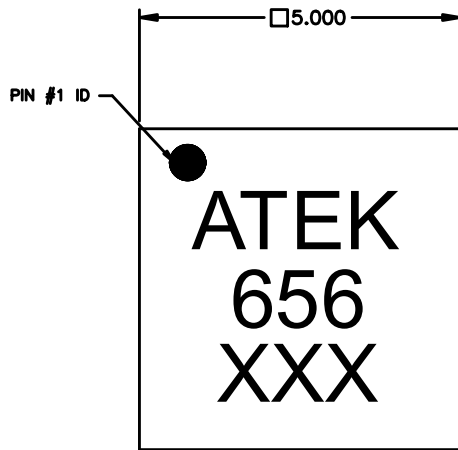

TOP VIEW

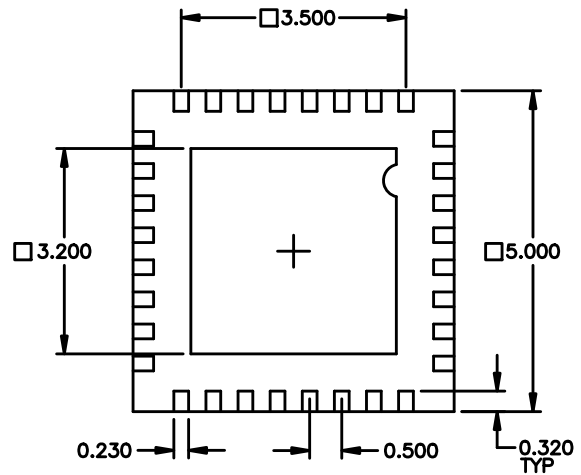

BOTTOM VIEW



SIDE VIEW

NOTES

1. ALL DIMENSIONS IN MM

## 2 - 18 GHz Switchable Filter Bank

### Handling Precautions



Caution!  
ESD-Sensitive Device  
Handle Accordingly

### Contact Information

For the latest specifications, additional product information, support, and sales.

Web: [www.atekmidas.com](http://www.atekmidas.com)

Tel: +90-212-483-71-67

Email: [support@atekmidas.com](mailto:support@atekmidas.com)

### Notice

This document and its contents are property of ATEK MIDAS. ATEK MIDAS has carefully reviewed the product specification information herein, and it is believed to be accurate and reliable. However, no responsibility is assumed for inaccuracies or errors, and the information within may be changed at any time without prior notice. Use of this information and/or any of our products does not convey to the user any patent rights or licenses. ATEK MIDAS products are designed to be used only within the electrical and environmental limits published in their respective data sheets or custom quoted specifications. ATEK MIDAS does not authorize the use of any of its products beyond the current published data sheet limits. Such use beyond the currently published electrical and/or environmental data sheet limits voids all ATEK MIDAS warranties. ATEK MIDAS reserves the right to change component circuitry, package material, assembly/test/inspect processes, specifications or other information at any time without prior notice. ATEK MIDAS shall have no responsibility for the customer's products, customer applications, and actions of the customer related to this product.

### Revisions

Revision No	Revision Date	Revision Reason	Section / Page No
1.0	05.07.2024	Initial Release	
1.1	05.08.2024	Plots and Electrical Specifications Sections Updated, Pin Description and Applications Information Sections Added	
1.2	30.01.2025	Switching Speed Data Added	
1.3	14.01.2026	Mechanical and Marking Information Revised	
1.4	04.02.2026	Pin Description Updated	
1.5	05.06.2026	Format & Content Updated	