

Product Description

ATEK590P2 is a cascadable single supply Gain Block Amplifier, input and output matched to 50 ohms and housed in low-cost 2x2 mm surface mount package.

Amplifier operation range covers Low Frequency to 3 GHz. Usable band low frequency cut off can go down to kHz region.

Evaluation Board, bare die, custom package, and module options are available upon request.

Product Features

- Frequency Range: LF - 3 GHz
- Gain: 20 dB
- OP1dB: 19.5 dBm
- OIP3: 36 dBm
- NF: 2.5 dB
- Single Supply

Applications

- Test Equipment
- Mobile Infrastructure
- SATCOM
- General Purpose Wireless
- Electronic Warfare

Functional Block Diagram

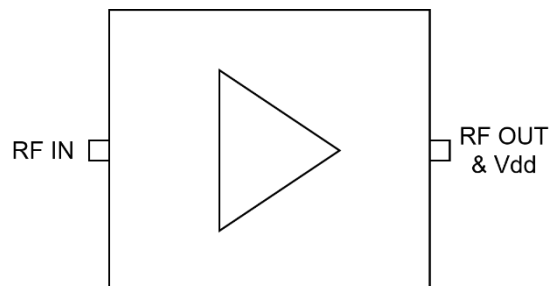

Electrical Specifications

Test conditions unless otherwise noted: 25 °C, V_{dd} = +5V.

Parameter		Min	Typ	Max	Units
Operational Frequency Range		LF		3	GHz
Gain	0.2 GHz		22		dB
	1 GHz		21		
	2 GHz		18.5		
	3 GHz		15.5		
Input Return Loss			12		dB
Output Return Loss			16		dB
Output P1dB			19.5		dBm
Output IP3			33		dBm
Noise Figure	0.2 GHz		2.2		dB
	1 GHz		2.7		
	2 GHz		3		
	3 GHz		3.9		
DC Supply Voltage		3	5	5.5	V
DC Supply Current (I _{dq})			92		mA
Operating Temperature		-40		85	°C

Typical Performance Plots

Conditions unless otherwise specified: $V_{dd} = +5\text{ V}$, $T=25\text{ C}$, CW.

Gain

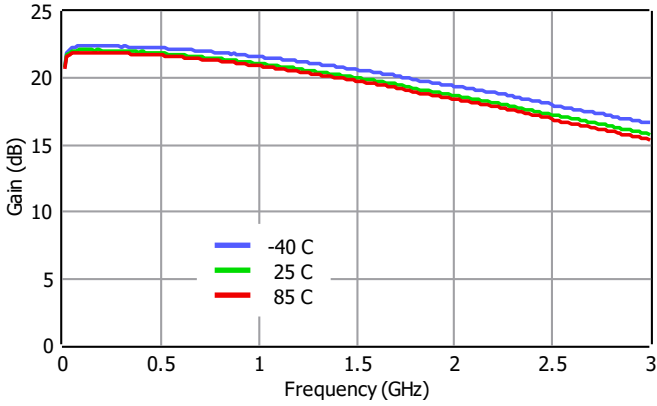

Isolation

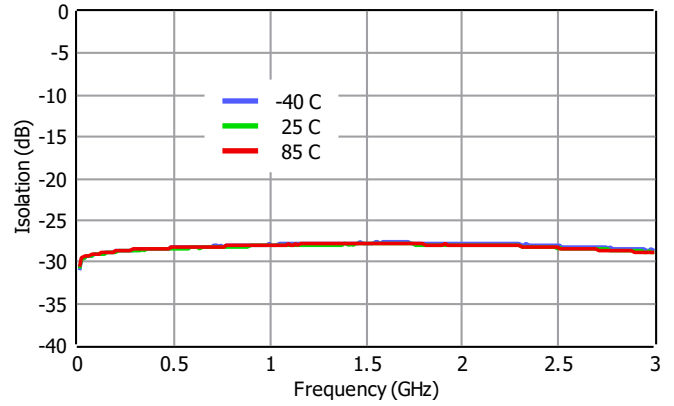

Input Return Loss

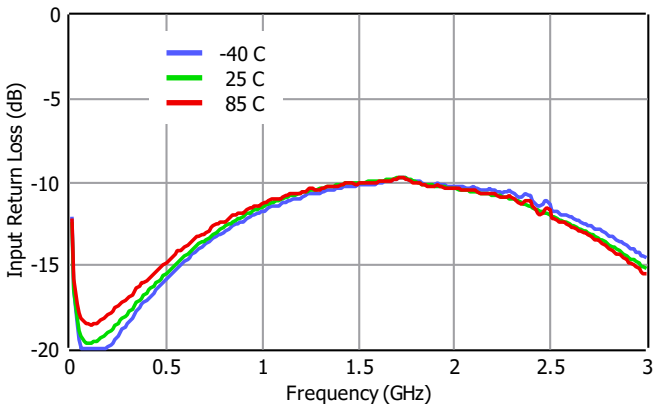

Output Return Loss

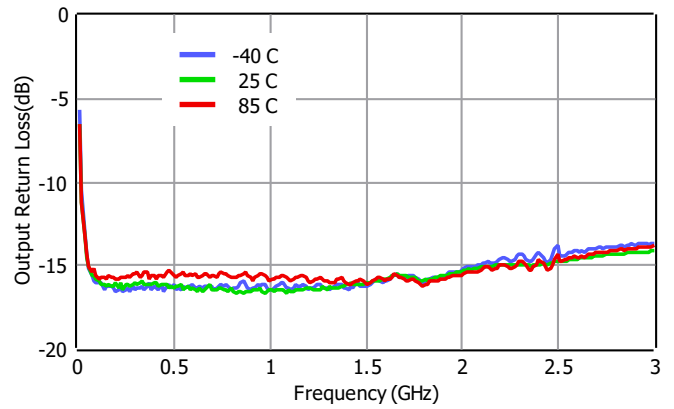

Noise Figure

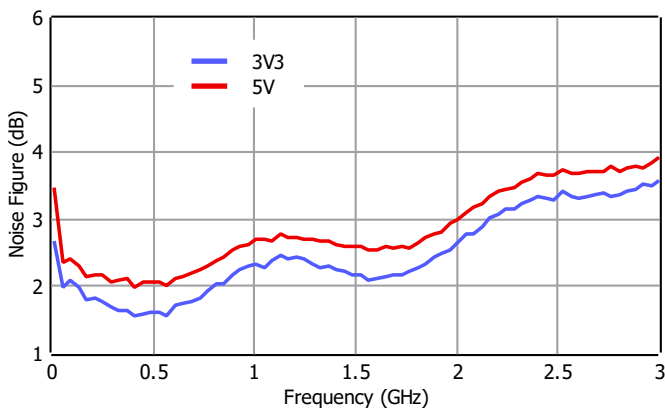

Output P1dB

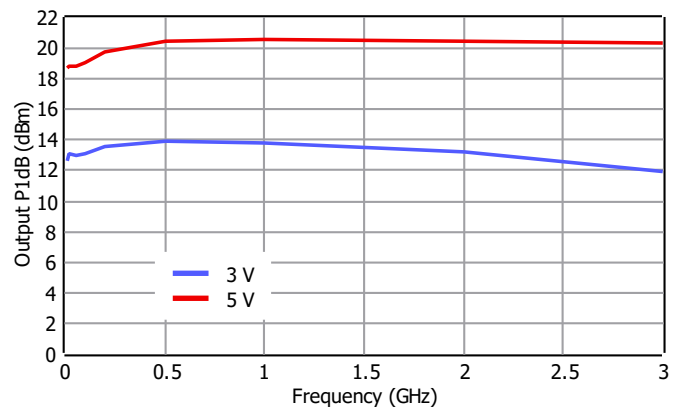

Pin Description

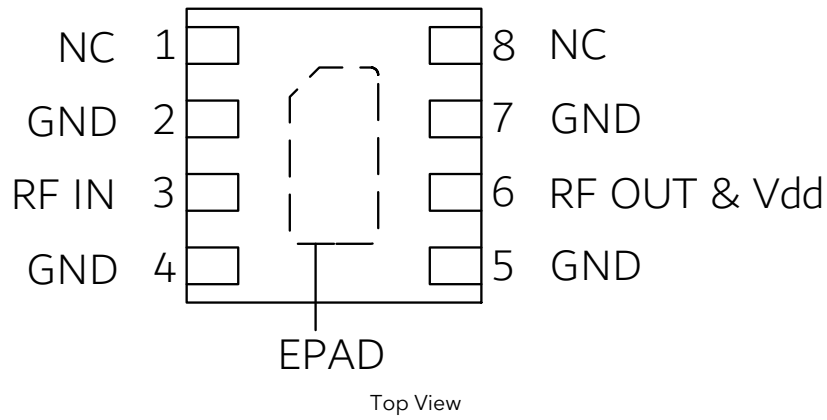

Pin Number	Pin Name	Description
3	RF IN	RF input pin. DC coupled; external DC block capacitor is required.
6	RF OUT & Vdd	RF output and Vdd supply pin. DC coupled; external DC block capacitor and RF choke inductor are required.
1, 8	NC	These pins are not internally connected. Can be grounded.
2, 4, 5, 7	GND	Ground.
11	EPAD	Exposed Pad on the bottom of the package should be connected to ground with multiple number of vias to reduce the inductance to the GND.

Applications Information

Signal entering from RF IN goes to RF OUT with an amplification.
Typical application schematic to operate the amplifier is given below.

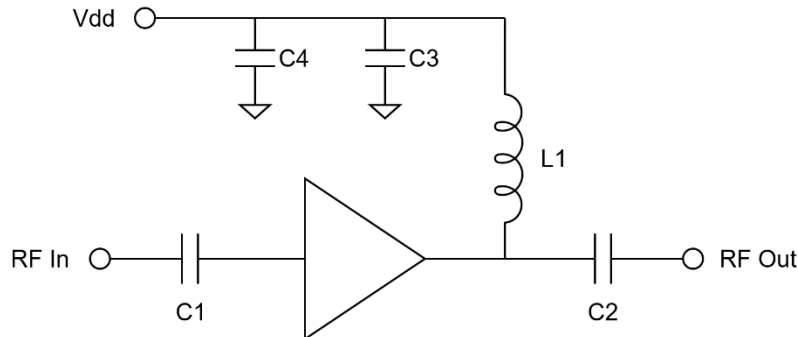

C1 and C2 are DC block capacitors. It is recommended to use wideband low loss DC block capacitors to achieve the best performance. Using low profile capacitors is also possible, which will result in additional loss.

L1 is used as RF choke inductor. It is recommended to use wideband RF choke to achieve wideband performance.

Choosing higher values for C1, C2 and L1 will allow amplifier to operate at lower frequencies, compared to the plots that is given in this datasheet. By increasing values of these components, low frequency operation down to kHz is possible.

C3 and C4 are used to filter out the ripples and unwanted signals coming from the Vdd supply. Using additional capacitors in parallel to C3 and C4 will improve this filtering. If this filtering is of no concern, then amplifier can be operated without C3 and C4.

Absolute Maximum Ratings

Parameter	Value /Range
Supply Voltage (Vdd)	TBD
Supply Current (Idd)	TBD
RF Input Power	TBD
Storage Temperature	-55 to +125 °C

Operation of this device outside the parameter ranges given above may cause damage. These parameters should not be applied simultaneously.

Mechanical and Marking Information

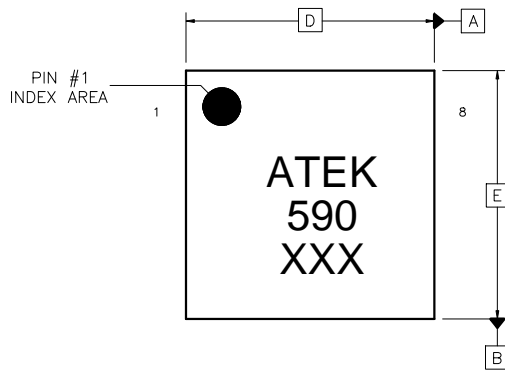

Top View

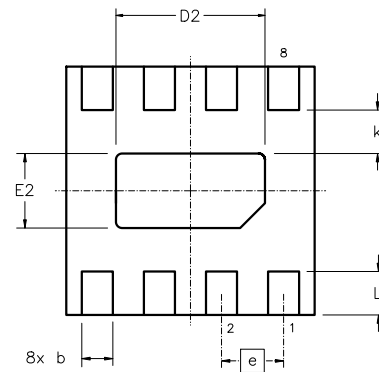

Bottom View

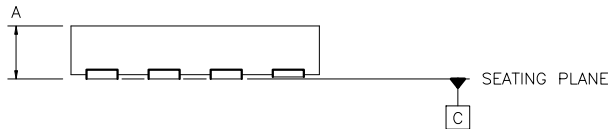

Side View

NOTES:
1) ALL DIMENSIONS IN MM

SYMBOL	MIN	MAX	SYMBOL	MIN	MAX
A, V	0.80	1.00	E2	0.50	0.70
b	0.18	0.30	e	0.50	BSC
D	2.00	BSC	k	0.20	-
D2	1.10	1.30	L	0.30	0.40
E	2.00	BSC			

Handling Precautions



Caution!
ESD-Sensitive Device
Handle Accordingly

Contact Information

For the latest specifications, additional product information, support, and sales.

Web: www.atekmidas.com

Tel: +90-212-483-71-67

Email: support@atekmidas.com

Notice

This document and its contents are property of ATEK MIDAS. ATEK MIDAS has the right to change the document at any time without notice. ATEK MIDAS distributes this document as a service to its customers. ATEK MIDAS supports its customers to help them create market leader products. Customer is responsible from choosing the product and the configuration the product. This document is provided `as is` and does not provide any warranty.

Customer is responsible for the usage of this document, the information provided in the document and the usage of products. ATEK MIDAS shall have no responsibility from the customer products, customer applications and doings of customers.

Revisions

Revision No	Revision Date	Revision Reason	Section / Page No
1.0	03.08.2021	Initial Release	
1.1	10.08.2022	Pin Description Revised	
1.2	08.01.2023	Format and Content Fixed	
1.3	19.06.2023	Temperature Measurement Added	
1.4	29.02.2024	Plot Added	