

Product Description

ATEK564P3 is a wideband driver amplifier covering 5 to 20 GHz frequency range. Amplifier can be used from 4 GHz.

ATEK564P3 provides flat gain over wideband with positive supply voltage. This allows users to easily realize wideband receiver frontends.

Amplifier housed in compact 3x3 mm low cost SMD package, input and output matched to 50 ohms internally. Evaluation Board, bare die, custom package, and module options are available upon request.

Product Features

- Frequency Range: 5 - 20 GHz
- Gain: 20 dB
- P1dB: 20.5 dBm
- Single Supply
- 3x3 mm compact size

Applications

- Wideband Receivers
- Telecommunication
- Test and Measurement
- SATCOM
- SDR

Functional Block Diagram

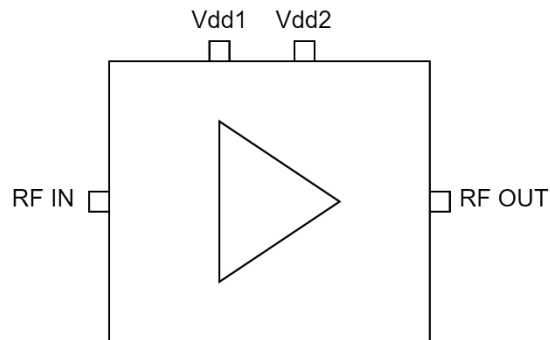

Electrical Specifications

Conditions unless otherwise specified: $V_{DD1} = V_{DD2} = 5V$, Typical, $T = 25\text{ C}$, CW.

Parameter		Min	Typ	Max	Units
Operational Frequency Range		4		20	GHz
Gain at 5V	5 GHz		19.4		dB
	8 GHz		19.7		
	12 GHz		20.8		
	16 GHz		22.1		
	20 GHz		17.8		
Gain at 3V	5 GHz		20		dB
	8 GHz		21.3		
	12 GHz		23		
	16 GHz		23.9		
	20 GHz		18		
Isolation at 5V	5 GHz		71		dB
	8 GHz		57		
	12 GHz		55		
	16 GHz		55		
	20 GHz		59		
Input Return Loss			-13		dB
Output Return Loss			-15		dB
Output IP3			30.5		dBm
Output P1dB at 5V			20.5		dBm
Output P1dB at 3V			16.5		dBm
Psat			TBD		dBm
Noise Figure			6		dB
DC Supply Voltage ($V_{DD1}=V_{DD2}$)			3 5		V
DC Supply Current			110 123		mA
Operating Temperature		-40		85	°C

Typical Performance Plots

Conditions unless otherwise specified: $V_{DD1} = V_{DD2} = 5\text{ V}$, Typical, $T = 25\text{ C}$, CW.

Gain

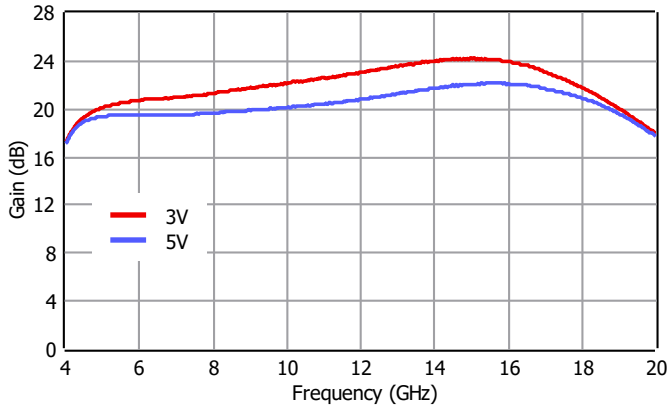

Gain Wideband

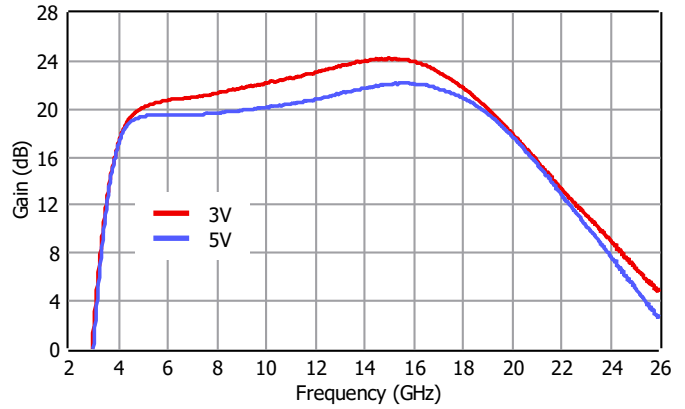

Input Return Loss

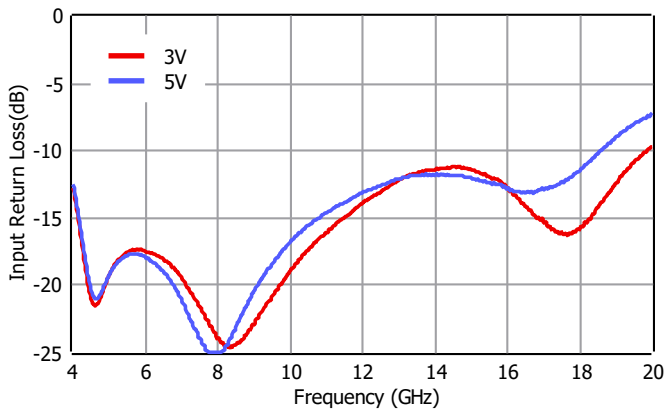

Output Return Loss

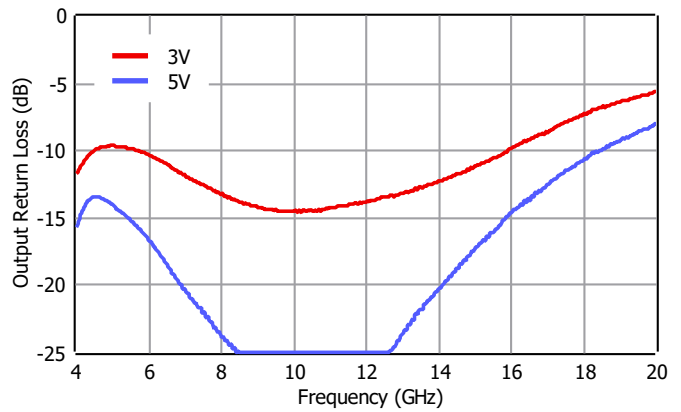

Isolation

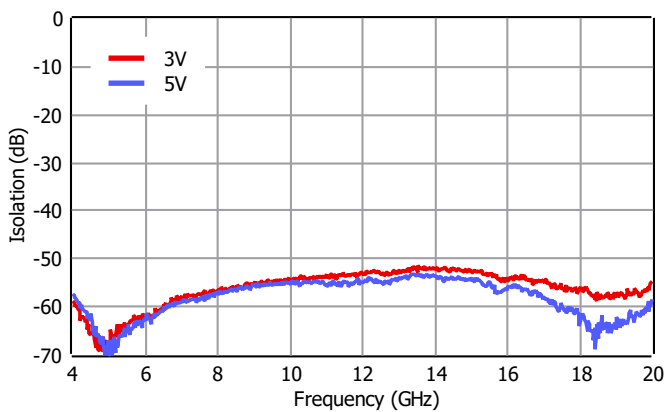

Noise Figure

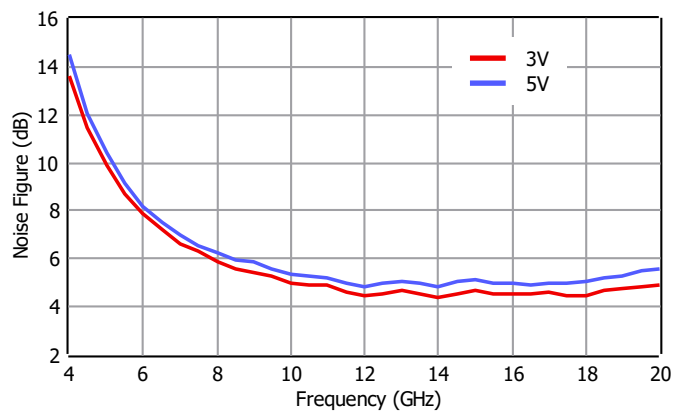

Typical Performance Plots

Conditions unless otherwise specified: $V_{DD1} = V_{DD2} = 5V$, Typical, $T = 25\text{ C}$, CW.

P1dB

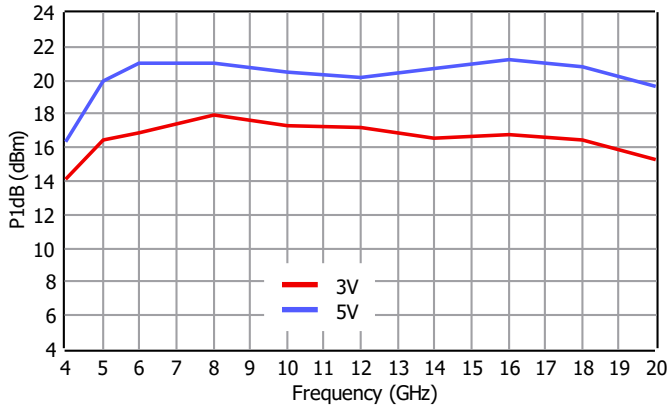

Current vs Output Power, Frequency

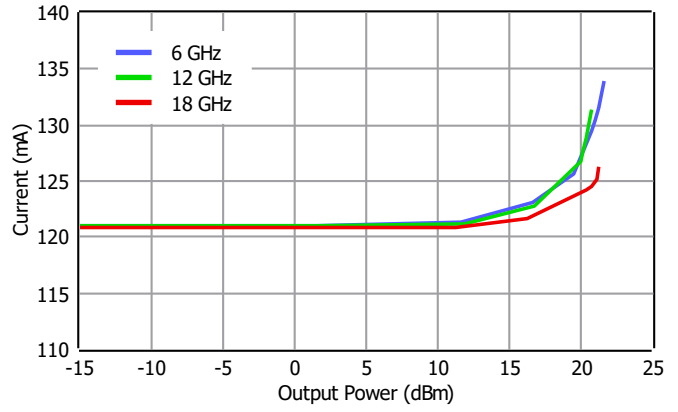

IP3

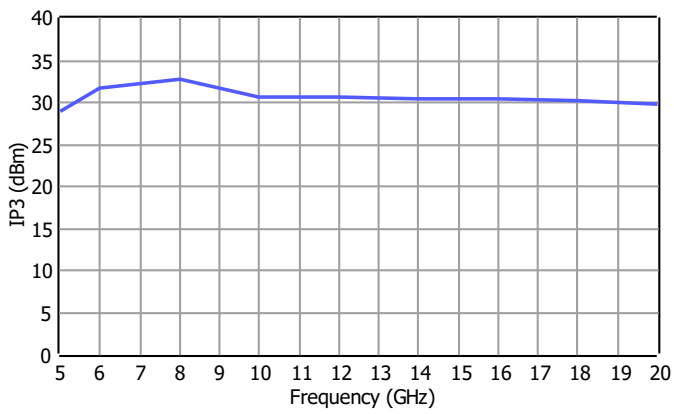

Pin Description

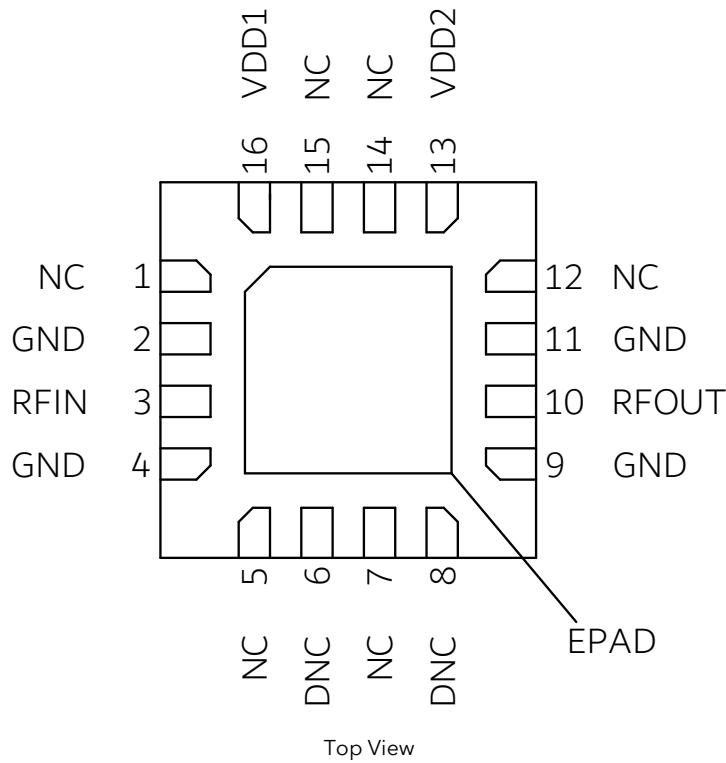

Pin Number	Pin Name	Description
3	RF IN	RF input pin. AC coupled.
10	RF OUT	RF output pin. AC coupled.
13	VDD1	Vdd bias pin.
16	VDD2	Vdd bias pin.
6, 8	DNC	These pins are used for internal purposes. They should be left open/floating.
1, 5, 7, 12, 14, 15	NC	These pins are not internally connected. Can be grounded on the PCB.
2, 4, 9, 11	GND	Ground.
17	EPAD	Exposed Pad on the bottom of the package should be connected to ground with multiple number of vias to reduce the inductance to the GND.

Applications Information

Signal entering from RF IN goes to RF OUT with an amplification.
Typical application schematic to operate the amplifier is given below.

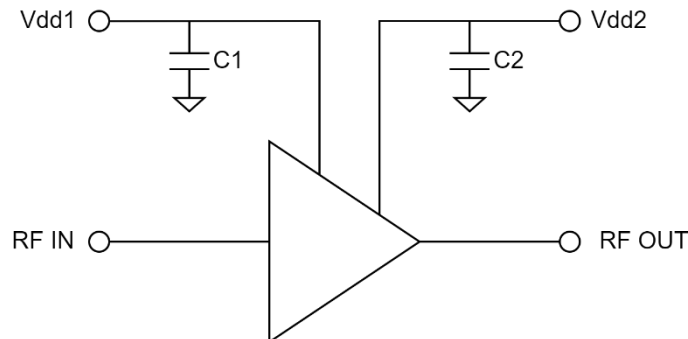

C1 and C2 are used to filter out the ripples and unwanted signals coming from the Vdd supply. Using additional capacitors in parallel to C1 and C2 will improve this filtering. If this filtering is of no concern, then amplifier can be operated without C1 and C2.

Small signal plots are gathered with probe PCB measurements, to generate data shown in this document.

Large signal and noise figure data are generated with connectorized evaluation PCB measurements. Then the PCB trace and connector transition losses are de-embedded, to generate plots shown in this document.

Vdd can be increased to 6V for higher P1dB performance.

The NC pins of the amplifier are connected to the GND on the PCBs used to generate the plots shown in this document.

Absolute Maximum Ratings

Parameter	Value/Range
Supply Voltage (Vdd)	TBD
RF Input Power	TBD
Storage Temperature	-55 to +125°C

Operation of this device outside the parameter ranges given above may cause damage. These conditions should not be applied simultaneously.

Mechanical and Marking Information

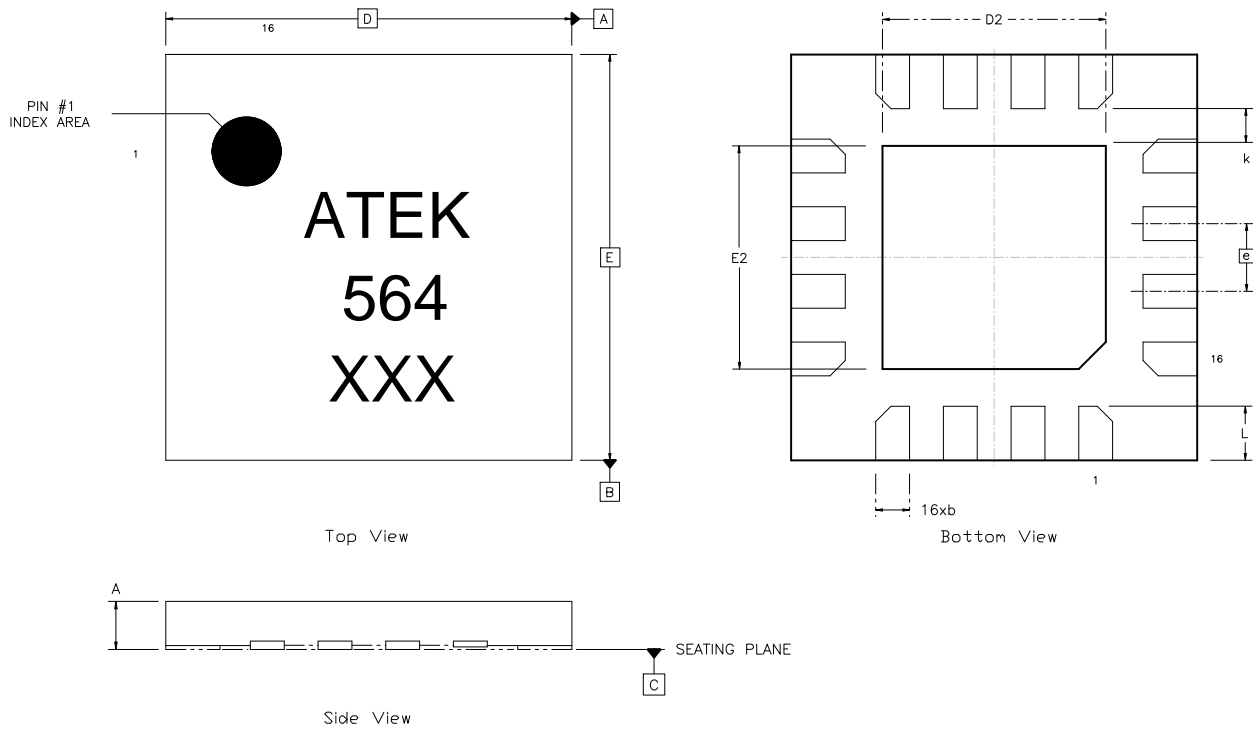

NOTES:
1) ALL DIMENSIONS IN MM

SYMBOL	MIN	MAX	SYMBOL	MIN	MAX
A, V	0.80	1.00	E2	1.55	1.75
b	0.18	0.30	e	0.50	BSC
D	3.00	BSC	k	0.20	-
D2	1.55	1.75	L	0.35	0.45
E	3.00	BSC			

Handling Precautions



Caution!
ESD-Sensitive Device
Handle Accordingly

Contact Information

For the latest specifications, additional product information, support, and sales.

Web: www.atekmidas.com

Tel: +90-212-483-71-67

Email: support@atekmidas.com

Notice

This document and its contents are property of ATEK MIDAS. ATEK MIDAS has the right to change the document at any time without notice. ATEK MIDAS distributes this document as a service to its customers. ATEK MIDAS supports its customers to help them create market leader products. Customer is responsible from choosing the product and the configuration the product. This document is provided `as is` and does not provide any warranty.

Customer is responsible for the usage of this document, the information provided in the document and the usage of products. ATEK MIDAS shall have no responsibility from the customer products, customer applications and doings of customers.

Revisions

Revision No	Revision Date	Revision Reason	Section / Page No
1.0	22.01.2024	Initial Release	
1.1	06.05.2024	Large Signal Data Added	