

## Product Description

ATEK564AN3 is a wideband driver amplifier covering 5 to 22 GHz frequency range. Amplifier can be used from 4 to 24 GHz.

ATEK564AN3 provides flat gain over wideband with positive supply voltage. This allows users to easily realize wideband receiver frontends.

Amplifier housed in compact 3x3 mm low cost SMD package, input and output matched to 50 ohms internally. Evaluation Board, bare die, custom package, and module options are available upon request.

## Product Features

- Frequency Range: 5 - 22 GHz
- Gain: 23 dB
- P1dB: 21.5 dBm
- Single Supply
- 3x3 mm compact size

## Applications

- Wideband Receivers
- Telecommunication
- Test and Measurement
- SATCOM
- SDR

## Functional Block Diagram

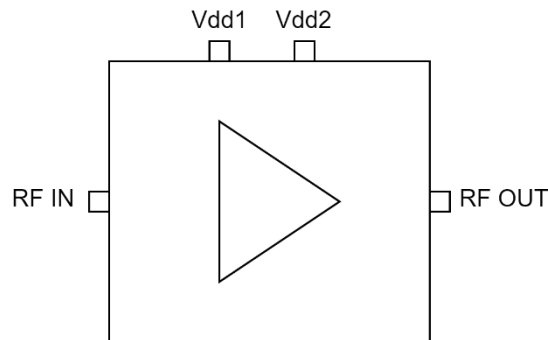

## Electrical Specifications

Conditions unless otherwise specified:  $V_{DD1} = V_{DD2} = 5\text{ V}$ ,  $I_{DQ} = 123\text{ mA}$ , Typical,  $T = 25\text{ C}$ , CW.

Parameter		Min	Typ	Max	Units
Operational Frequency Range		4		22	GHz
Gain at 5V	5 GHz		22.4		dB
	8 GHz		22		
	12 GHz		22.7		
	18 GHz		24.2		
	22 GHz		20.7		
Gain at 3V	5 GHz		22.8		dB
	8 GHz		23.7		
	12 GHz		24.7		
	18 GHz		25.8		
	22 GHz		20.8		
Isolation at 5V	5 GHz		67		dB
	8 GHz		59		
	12 GHz		56		
	18 GHz		52		
	22 GHz		66		
Input Return Loss			-13		dB
Output Return Loss			-15		dB
Output IP3			30.5		dBm
Output P1dB at 5V			21.5		dBm
Output P1dB at 3.3V			18		dBm
Psat			22.5		dBm
Noise Figure			6		dB
DC Supply Voltage ( $V_{DD1}=V_{DD2}$ )			3.3	5	V
DC Supply Current at Configuration A			115	123	mA
DC Supply Current at Configuration B			140	147	
Operating Temperature		-40		85	°C

### Typical Performance Plots

Conditions unless otherwise specified:  $V_{DD1} = V_{DD2} = 5\text{ V}$ , Typical,  $T = 25\text{ C}$ , CW.

Gain

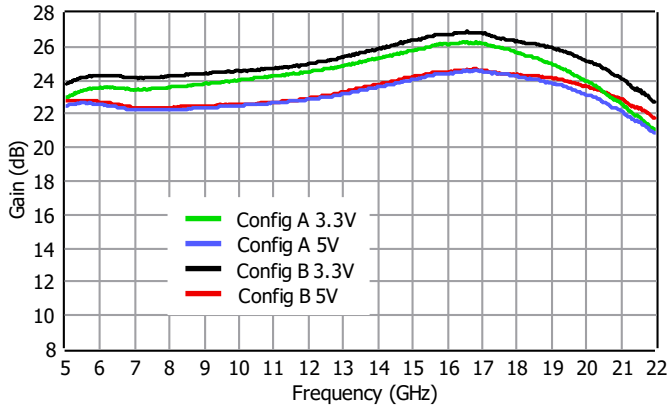

Gain Wideband

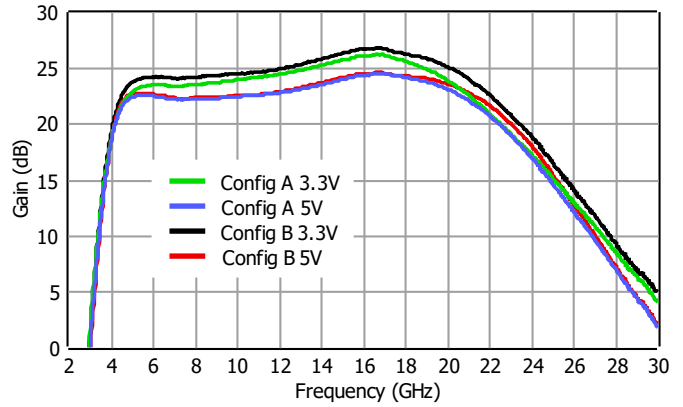

Input Return Loss

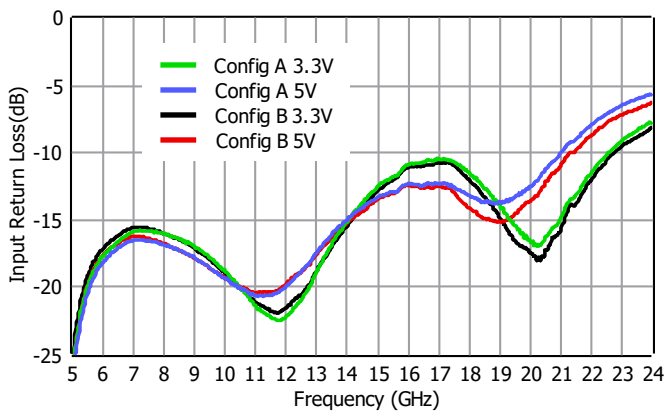

Output Return Loss

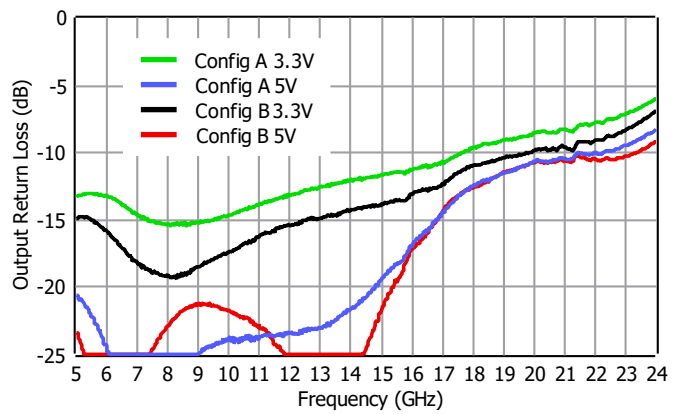

Isolation

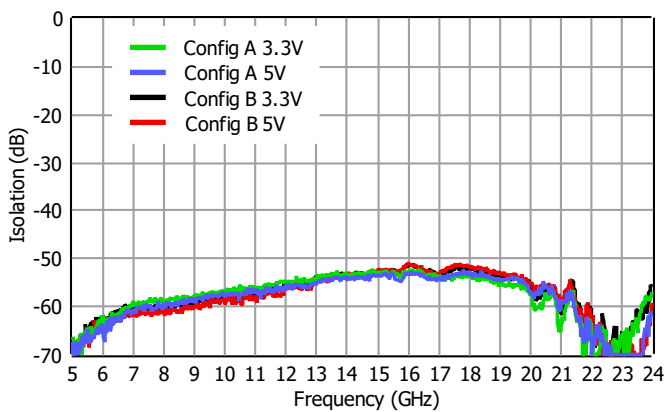

### Typical Performance Plots

Conditions unless otherwise specified:  $V_{DD1} = V_{DD2} = 5\text{ V}$ , Typical,  $T = 25\text{ C}$ , CW.

Gain vs Temperature

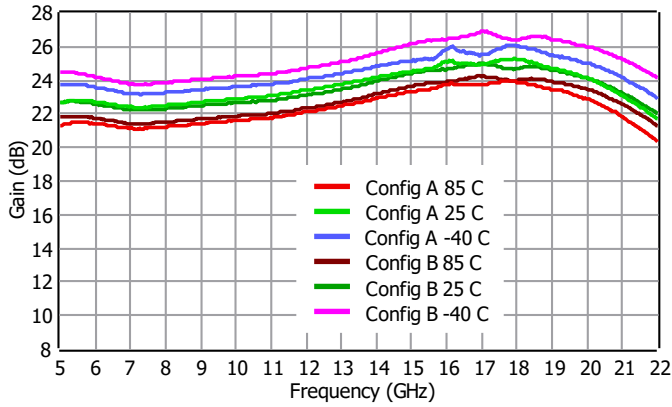

Gain Wideband vs Temperature

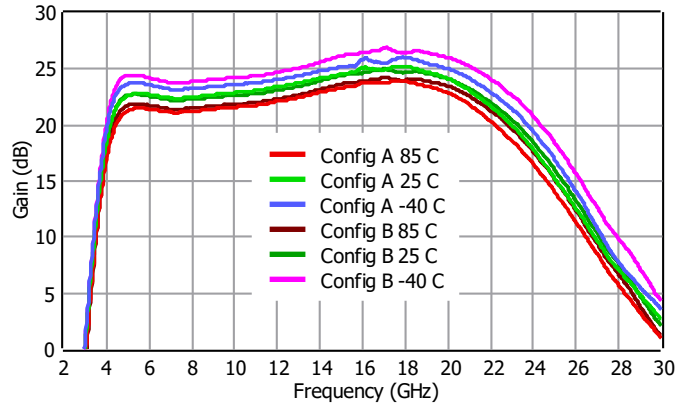

Input Return Loss vs Temperature

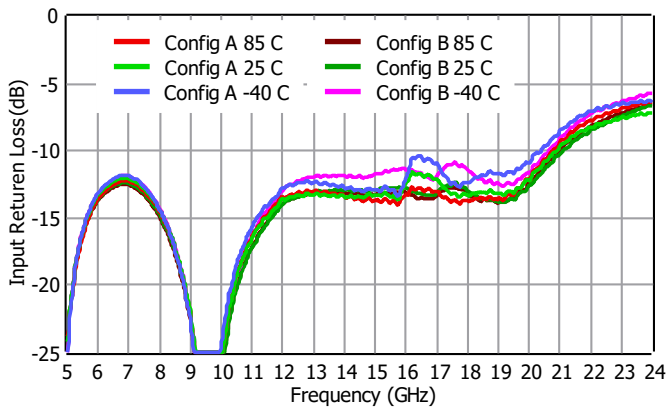

Output Return Loss vs Temperature

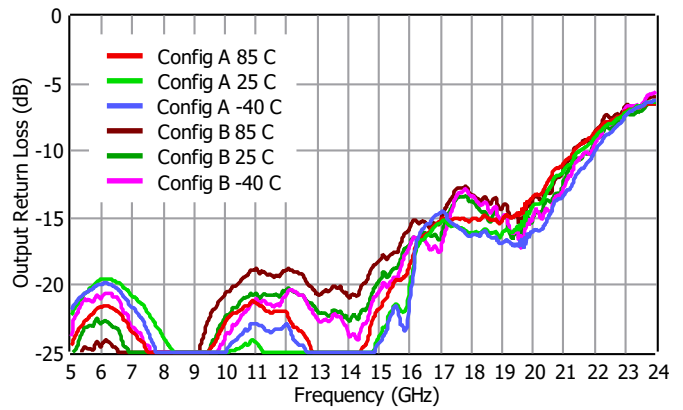

Isolation vs Temperature

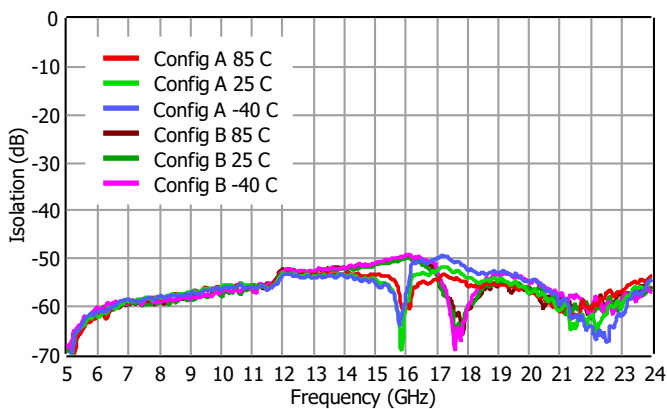

## Typical Performance Plots

Conditions unless otherwise specified:  $V_{DD1} = V_{DD2} = 5V$ , Typical,  $T = 25\text{ C}$ , CW.

P1dB

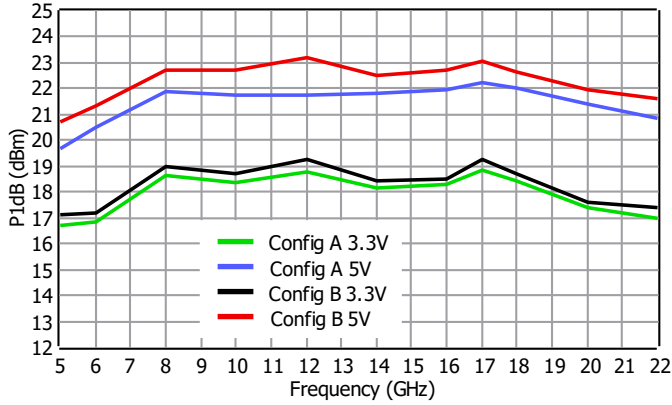

P1dB

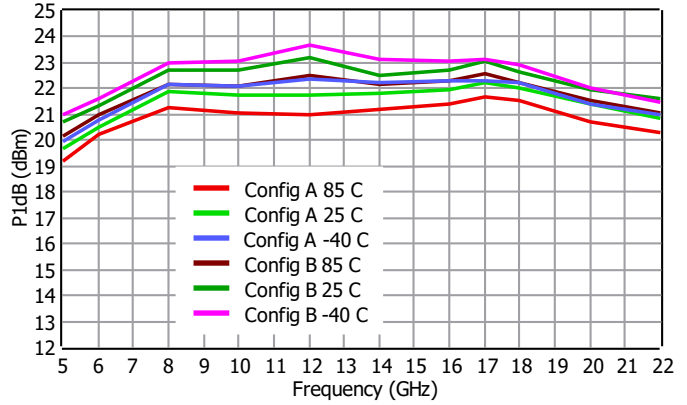

P1dB

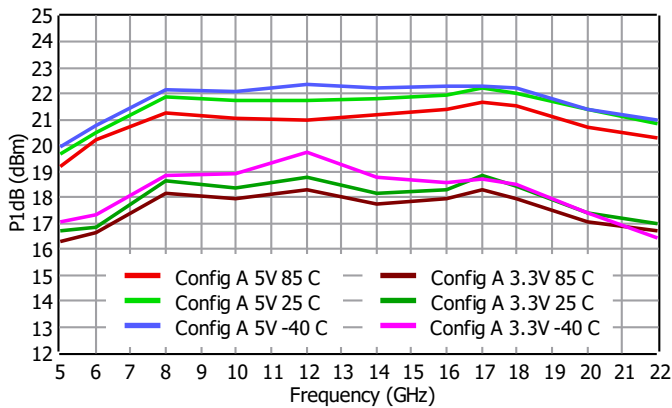

P1dB

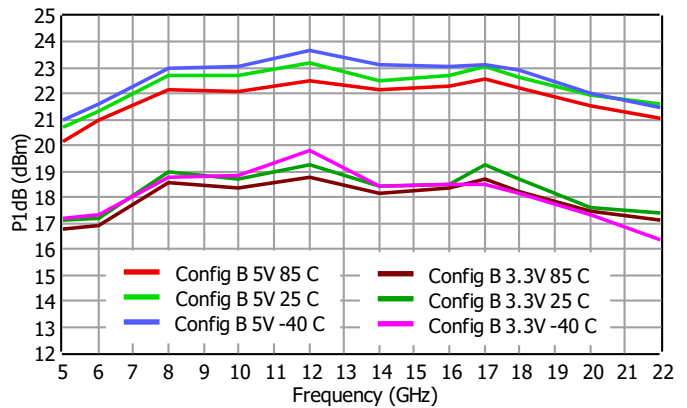

Psat

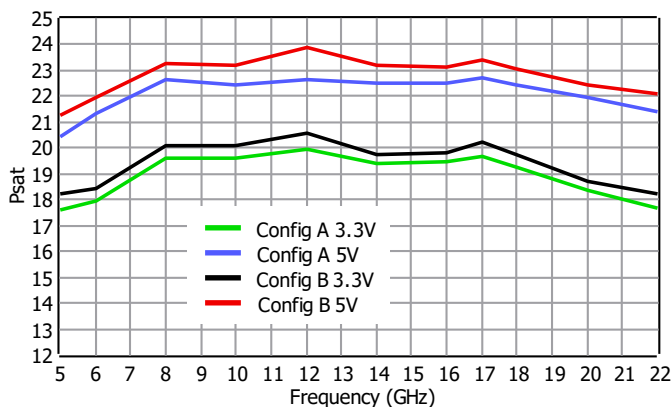

Psat

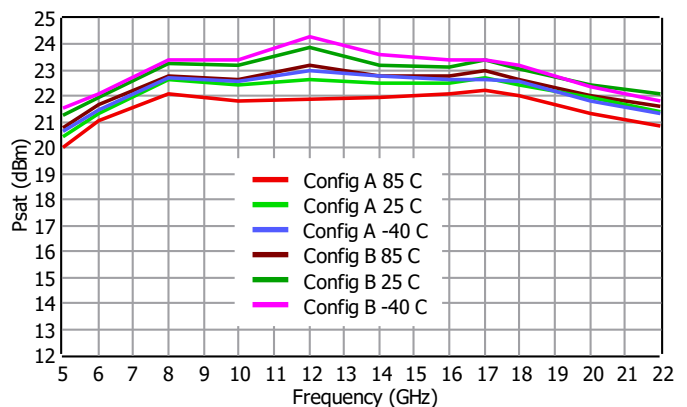

## Typical Performance Plots

Conditions unless otherwise specified:  $V_{DD1} = V_{DD2} = 5\text{ V}$ , Typical,  $T = 25\text{ C}$ , CW.

Psat

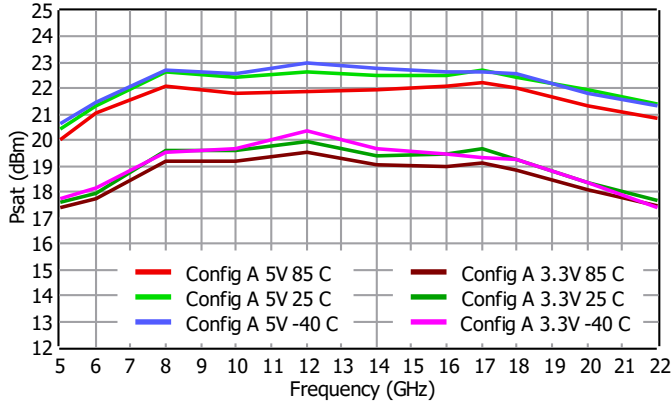

Psat

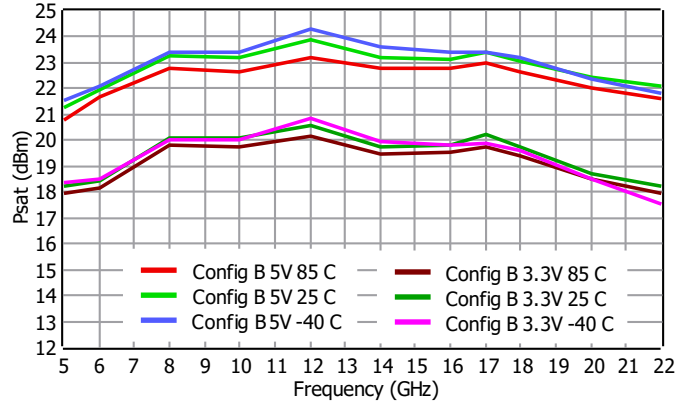

Current vs Output Power, Frequency at Config A

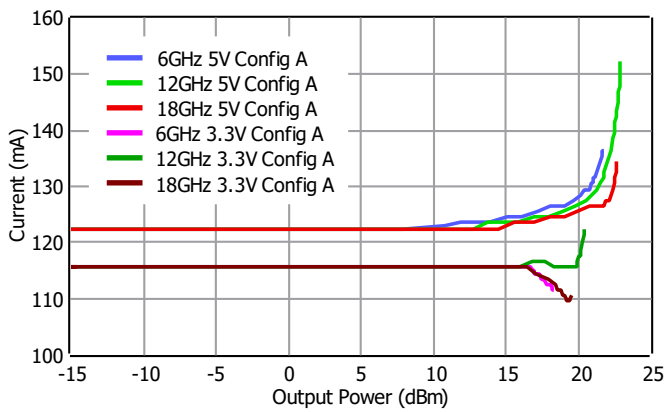

Current vs Output Power, Frequency at Config B

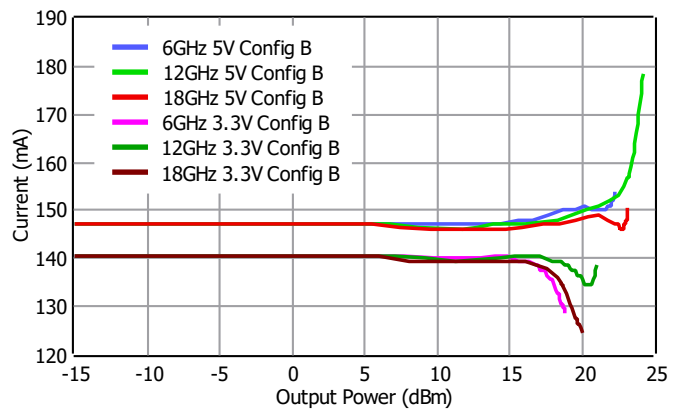

Output IP3

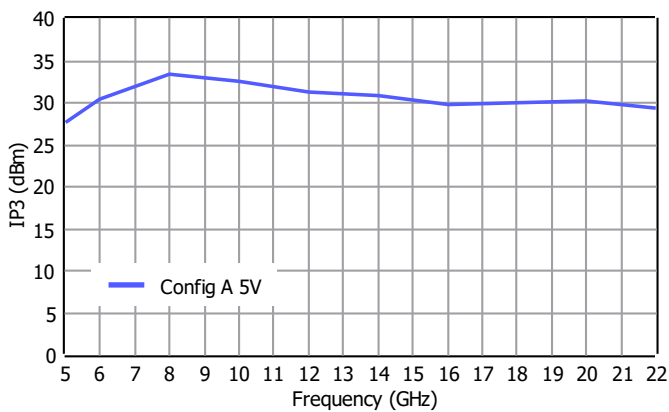

Noise Figure

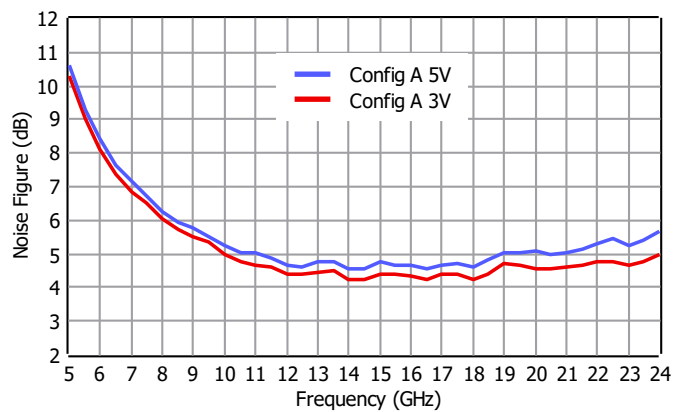

**Pin Description**

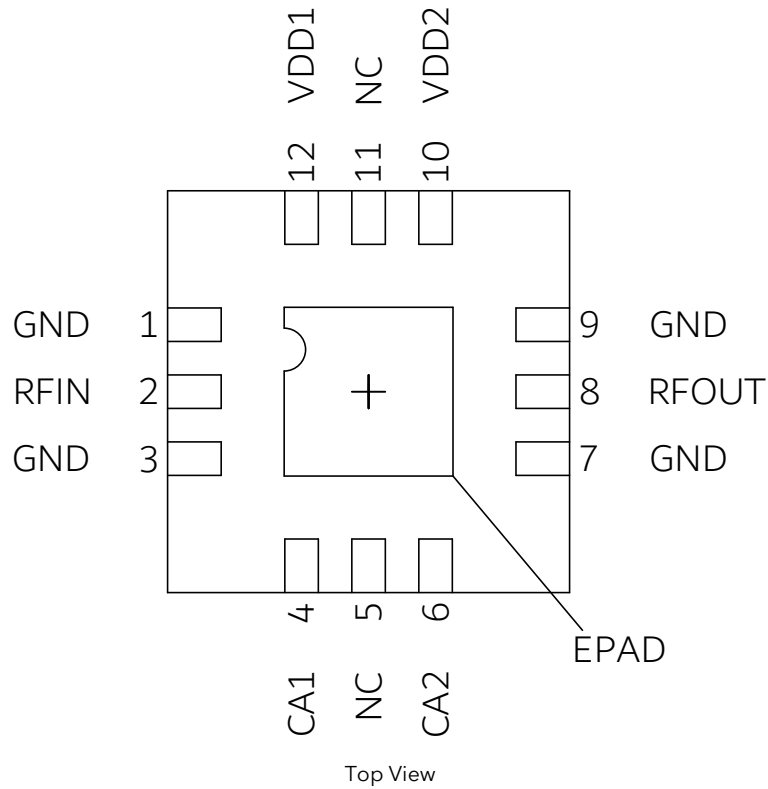

Pin Number	Pin Name	Description
2	RF IN	RF input pin. AC coupled.
8	RF OUT	RF output pin. AC coupled.
12	VDD1	Vdd bias pin.
10	VDD2	Vdd bias pin.
4	CA1	Current consumption adjustment pin. See Application Section for details.
6	CA2	Current consumption adjustment pin. See Application Section for details.
5, 11	NC	These pins are not internally connected. Can be grounded on the PCB.
1, 3, 7, 9,	GND	Ground.
13	EPAD	Exposed Pad on the bottom of the package should be connected to ground with multiple number of vias to reduce the inductance to the GND.

## Applications Information

Signal entering from RF IN goes to RF OUT with an amplification.  
Typical application schematic to operate the amplifier is given below.

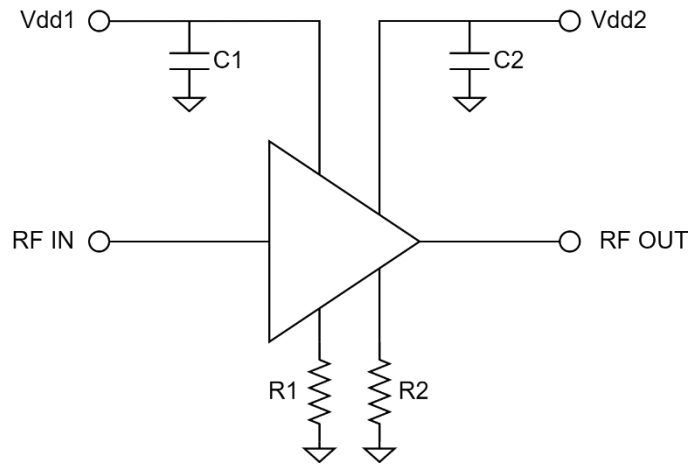

C1 and C2 are used to filter out the ripples and unwanted signals coming from the Vdd supply. Using additional capacitors in parallel to C1 and C2 will improve this filtering. If this filtering is of no concern, then amplifier can be operated without C1 and C2.

The amplifier has two configurations of operation. Leaving CA1 and CA2 pins floating or connecting to ground with 0-ohm R1 and R2 resistors sets the configuration state. By changing the configuration, the amplifier can provide higher P1dB at the expense of current consumption.

Configuration details for these pins are shown in the table below.

Configuration	CA1 and CA2 States	Voltage (V)	Typical Current (mA)
A	Open/floating	3.3	115
		5	123
B	Short to GND	3.3	140
		5	147

Small signal data at 25C only, are gathered with probe PCB measurements, to generate data shown in this document.

Over temperature small signal data for all temperatures are gathered by connectorized evaluation PCB measurements. Then the PCB trace and connector transition losses are de-embedded, to generate plots shown in this document.

Large signal and noise figure data are generated with connectorized evaluation PCB measurements. Then the PCB trace and connector transition losses are de-embedded, to generate plots shown in this document.

The NC pins of the amplifier are connected to the GND on the PCBs used to generate the plots shown in this document.

## Absolute Maximum Ratings

Parameter	Value/Range
Supply Voltage (Vdd)	6 V
RF Input Power	+10 dBm
Storage Temperature	-55 to +125°C

Operation of this device outside the parameter ranges given above may cause damage. These conditions should not be applied simultaneously.

## Mechanical and Marking Information

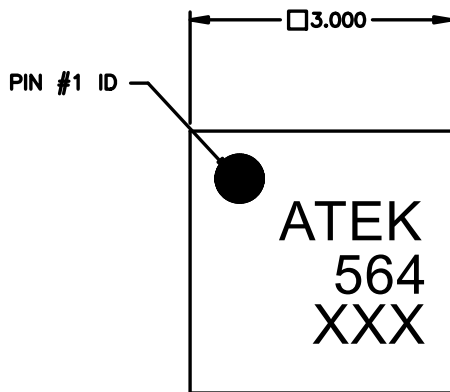

**TOP VIEW**

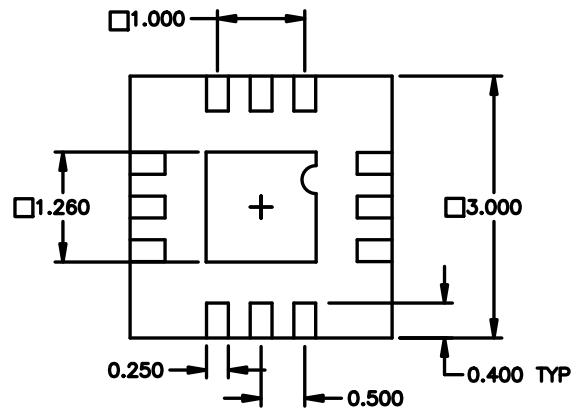

**BOTTOM VIEW**

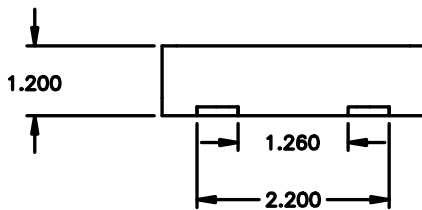

**SECTION A-A**

### NOTES

1. ALL DIMENSIONS IN MM
2. LEADFRAME MATERIAL: COPPER ALLOY
3. LEAD FINISH:  
Au, 1 $\mu$ m - 2 $\mu$ m  
Ni, 2.5 $\mu$ m - 7.6 $\mu$ m

## Handling Precautions



Caution!  
ESD-Sensitive Device  
Handle Accordingly

## Contact Information

For the latest specifications, additional product information, support, and sales.

Web: [www.atekmidas.com](http://www.atekmidas.com)

Tel: +90-212-483-71-67

Email: [support@atekmidas.com](mailto:support@atekmidas.com)

## Notice

This document and its contents are property of ATEK MIDAS. ATEK MIDAS has the right to change the document at any time without notice. ATEK MIDAS distributes this document as a service to its customers. ATEK MIDAS supports its customers to help them create market leader products. Customer is responsible from choosing the product and the configuration the product. This document is provided `as is` and does not provide any warranty.

Customer is responsible for the usage of this document, the information provided in the document and the usage of products. ATEK MIDAS shall have no responsibility from the customer products, customer applications and doings of customers.

## Revisions

Revision No	Revision Date	Revision Reason	Section / Page No
1.0	05.01.2024	Initial Release	
1.1	11.01.2024	Plots Added	
1.2	18.01.2024	Format and Content Fixed	
1.3	06.05.2024	Large Signal Data Added	
2.0	26.12.2024	Temperature measurement data and Configuration Pins Added	
2.1	30.12.2024	Format and Content Fixed	
2.2	14.01.2025	Mechanical and Marking Information Updated	
2.3	16.01.2025	Mechanical and Marking Information Updated	