

Product Description

ATEK550P3 is an RF amplifier covering 5 to 12 GHz frequency range.

Amplifier is biased with a single positive supply, input and outputs are matched to 50 ohms internally, has internal DC block capacitors. These features allow users to easily integrate the amplifier into RF transmit receive chains.

Amplifier housed in compact 3x3 mm low cost SMD package, input and output matched to 50 ohms internally. Evaluation Board, bare die, custom package, and module options are available upon request.

Product Features

- Frequency Range: 5 - 12 GHz
- Gain: 17 dB at 8 GHz
- Single Supply
- 3x3 mm compact size

Applications

- Wideband Receivers
- Telecommunication
- SATCOM
- SDR
- Test Equipment

Functional Block Diagram

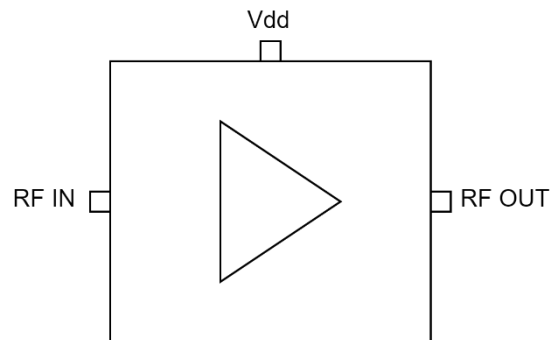

Electrical Specifications

Conditions unless otherwise specified: $V_{DD} = 5\text{ V}$, Typical, $T = 25\text{ C}$, CW.

Parameter		Min	Typ	Max	Units
Operational Frequency Range		5		12	GHz
Gain	5 GHz		14.2		dB
	6 GHz		17		
	8 GHz		17.2		
	10 GHz		15.8		
	12 GHz		13.7		
Input Return Loss			-15		dB
Output Return Loss			-18		dB
Output P1dB			17.5		dBm
Output IP3			29		dBm
Psat			20		dBm
DC Supply Voltage (Vdd)			3.3 5		V
DC Supply Current			58 97		mA
Operating Temperature		-40		85	°C

Typical Performance Plots

Conditions unless otherwise specified: $V_{DD} = 5V$, Typical, $T = 25\text{ C}$, CW.

Gain

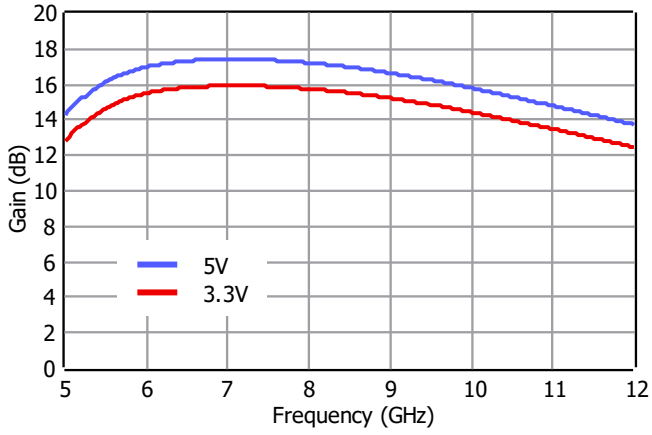

Gain

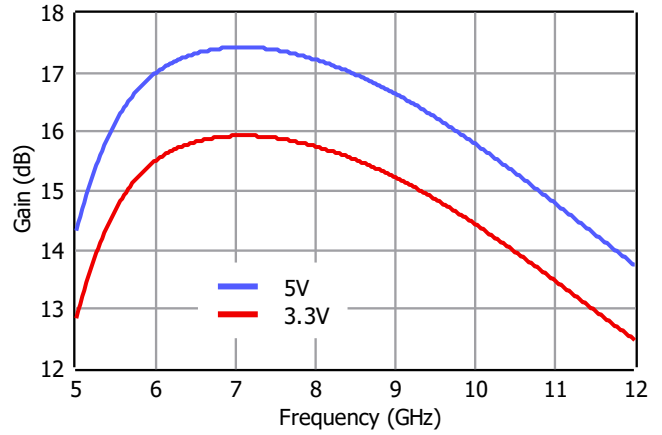

Input Return Loss

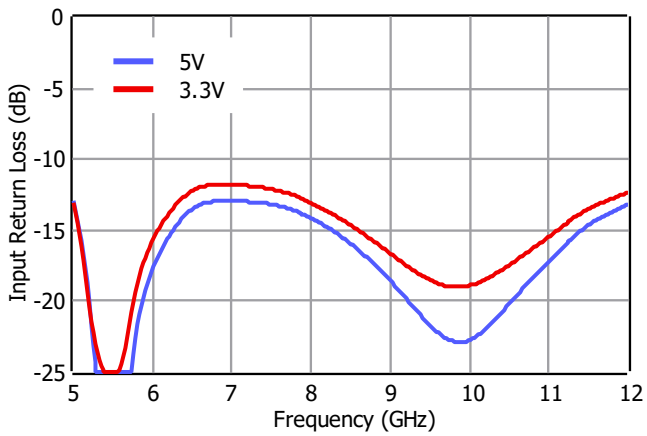

Output Return Loss

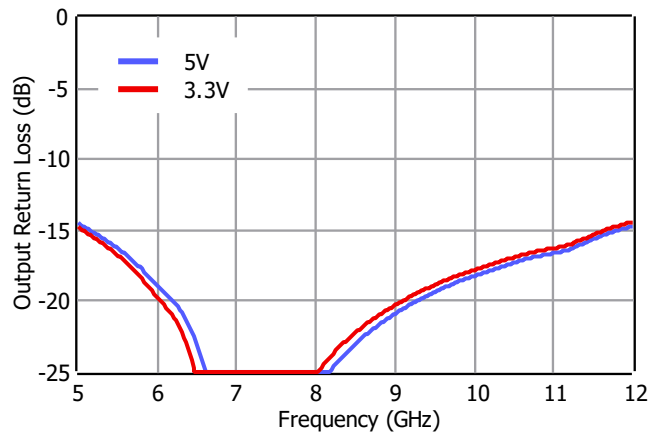

Isolation

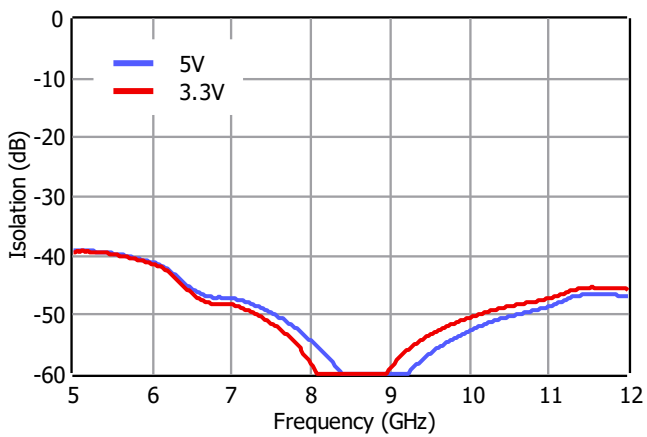

Typical Performance Plots

Conditions unless otherwise specified: $V_{DD} = 5V$, Typical, $T = 25\text{ C}$, CW.

OIP3

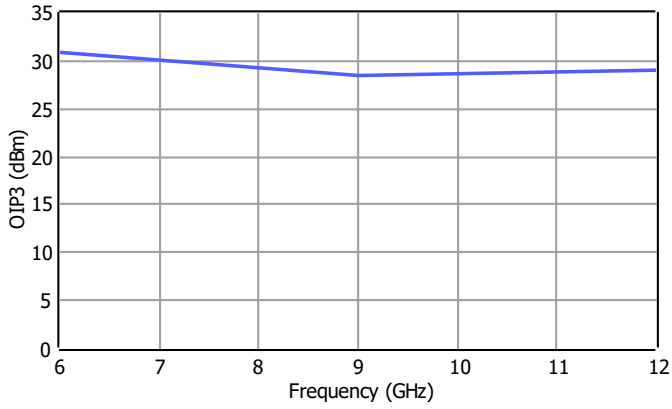

OP1dB

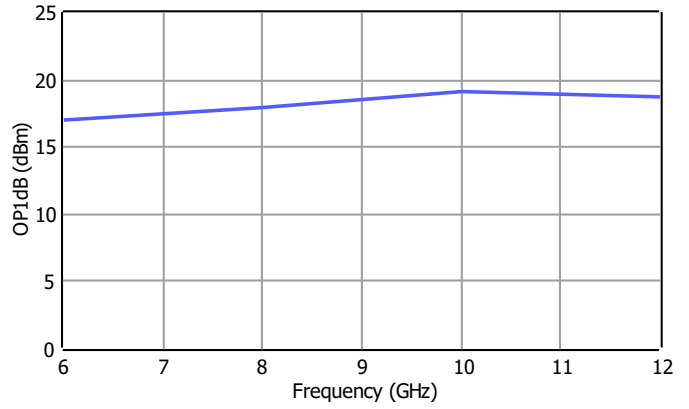

Psat

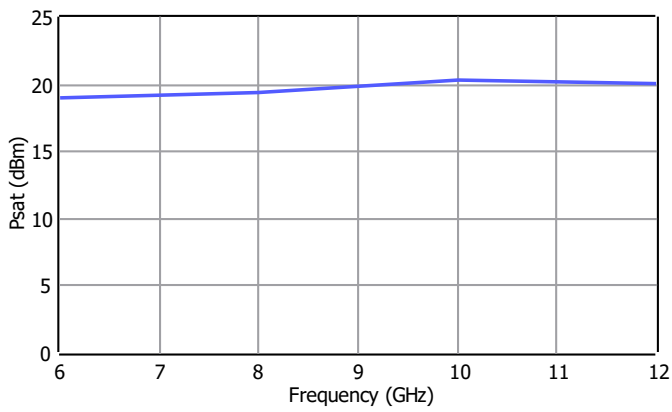

Noise Figure

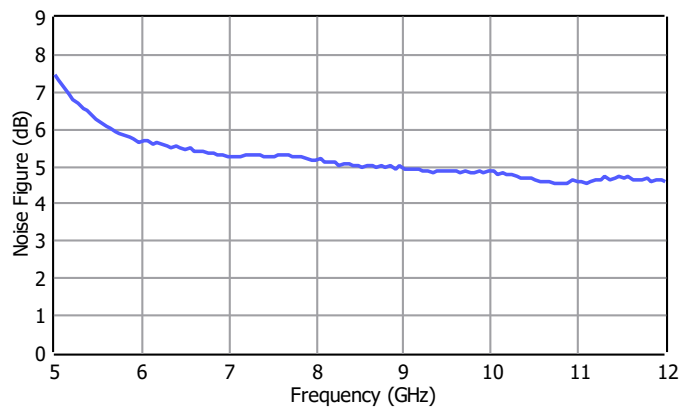

Pin Description

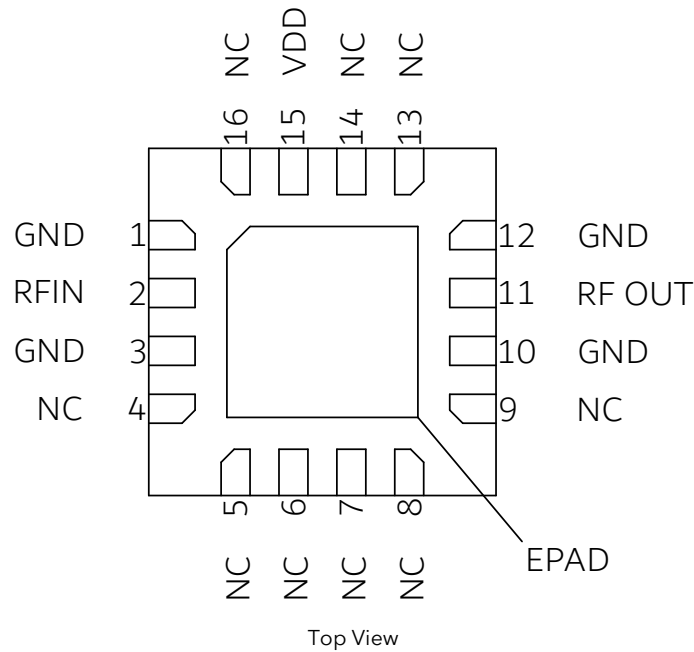

Pin Number	Pin Name	Description
2	RF IN	RF input pin. AC coupled.
11	RF OUT	RF output pin. AC coupled.
15	VDD	Vdd bias pin.
4-9, 13, 14, 16	NC	These pins are not internally connected. Can be grounded on the PCB.
1, 3, 10, 12	GND	Ground.
17	EPAD	Exposed Pad on the bottom of the package should be connected to ground with multiple number of vias to reduce the inductance to the GND.

Applications Information

Signal entering from RF IN goes to RF OUT with an amplification.
Typical application schematic to operate the amplifier is given below.

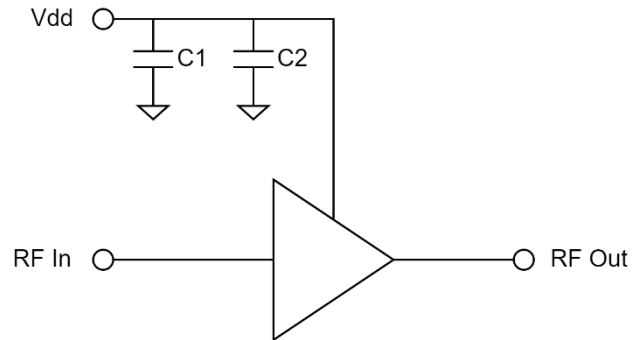

C1 and C2 are used to filter out the ripples and unwanted signals coming from the Vdd supply. Using additional capacitors in parallel to C1 and C2 will improve this filtering. If this filtering is of no concern, then amplifier can be operated without C1 and C2.

The NC pins of the Amplifier are connected to the GND on the evaluation PCBs used to generate the plots shown in this document.

Absolute Maximum Ratings

Parameter	Value/Range
Supply Voltage (Vdd)	TBD
RF Input Power	TBD
Storage Temperature	-55 to +125°C

Operation of this device outside the parameter ranges given above may cause damage. These conditions should not be applied simultaneously.

Mechanical and Marking Information

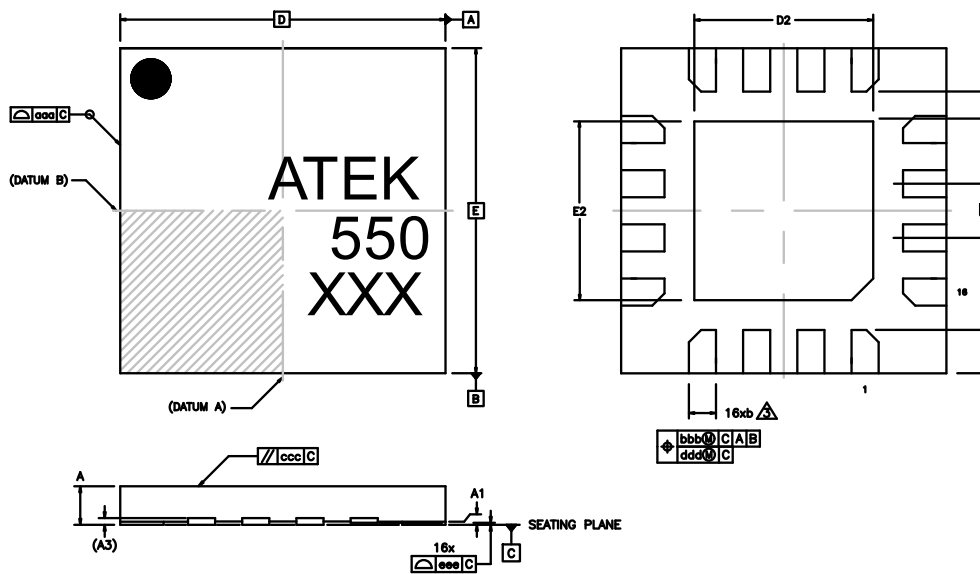

NOTES:
1) ALL DIMENSIONS IN MM
2) DIMENSIONING AND TOLERANCING PER ASME Y14.5-2009
3) DIMENSION b APPLIES TO METALLIZED TERMINAL AND IS MEASURED BETWEEN 0.15 AND 0.30 MM FROM TERMINAL TIP

SYMBOL	MIN	MAX	SYMBOL	MIN	MAX
A, V	0.80	1.00	E2	1.55	1.75
A, W	0.70	0.80	e	0.50	BSC
A, L	1.40	1.70	k	0.20	-
A1	0.00	0.05	L	0.35	0.45
A3	0.20	REF	ooo		0.10
b	0.18	0.30	bbb		0.10
D	3.00	BSC	ccc		0.10
D2	1.55	1.75	ddd		0.05
E	3.00	BSC	eee		0.08

Handling Precautions



Caution!
ESD-Sensitive Device
Handle Accordingly

Contact Information

For the latest specifications, additional product information, support, and sales.

Web: www.atekmidas.com

Tel: +90-212-483-71-67

Email: support@atekmidas.com

Notice

This document and its contents are property of ATEK MIDAS. ATEK MIDAS has the right to change the document at any time without notice. ATEK MIDAS distributes this document as a service to its customers. ATEK MIDAS supports its customers to help them create market leader products. Customer is responsible from choosing the product and the configuration the product. This document is provided `as is` and does not provide any warranty.

Customer is responsible for the usage of this document, the information provided in the document and the usage of products. ATEK MIDAS shall have no responsibility from the customer products, customer applications and doings of customers.

Revisions

Revision No	Revision Date	Revision Reason	Section / Page No
1.0	04.06.2022	Initial Release	