

## Product Description

ATEK367P4 is an analog phase shifter covering 2 to 4 GHz frequency range, providing continuously adjustable monotonic phase shift from 0 to 375 degrees via an analog control voltage.

Phase shifter is housed in compact 4x4 mm low cost SMD package, input and output matched to 50 ohms internally. Evaluation Board, bare die, custom package, and module options are available upon request.

## Product Features

- Frequency Range: 2-4 GHz
- Phase Shift: 375 degrees
- Insertion Loss: 3 dB
- Single Supply
- 4x4 mm compact size

## Applications

- Wideband Receivers
- Telecommunication
- Test and Measurement
- SATCOM
- SDR

## Functional Block Diagram

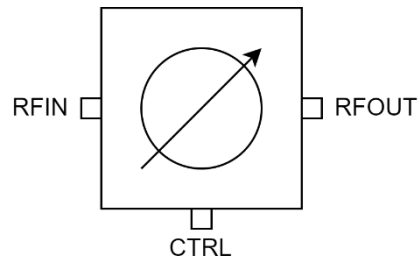

## Electrical Specifications

Conditions unless otherwise specified: Typical, T = 25 C, CW.

Parameter		Min	Typ	Max	Units
Operational Frequency Range		2		4	GHz
Insertion Loss at 2.4 GHz	0 V		4.1		dB
	2 V		3.1		
	4 V		2.7		
	8 V		2.6		
	10 V		2.6		
Normalized Phase Shift at 2.4 GHz	0 V		0		degrees
	2 V		185		
	4 V		290		
	8 V		370		
	10 V		375		
Input Return Loss			-11		dB
Output Return Loss			-12		dB
Input IP3			TBD		dBm
Input P1dB			20		dBm
DC Control Voltage (CTRL)		0		10	V
DC Current (Ictrl)			0.2		mA
Operating Temperature		-40		85	°C

## Typical Performance Plots

Conditions unless otherwise specified: Typical, T = 25 C, CW.

Insertion Loss

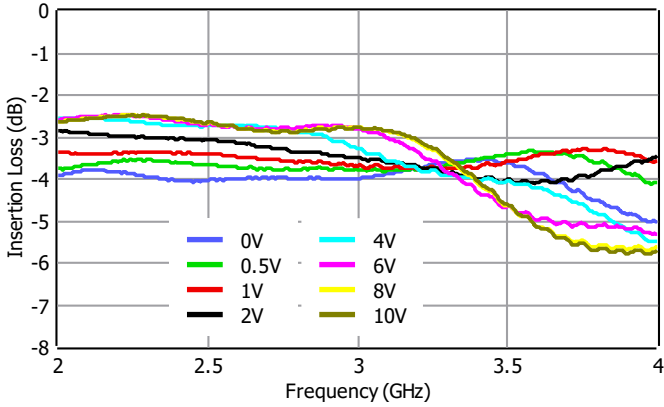

Normalized Phase Shift

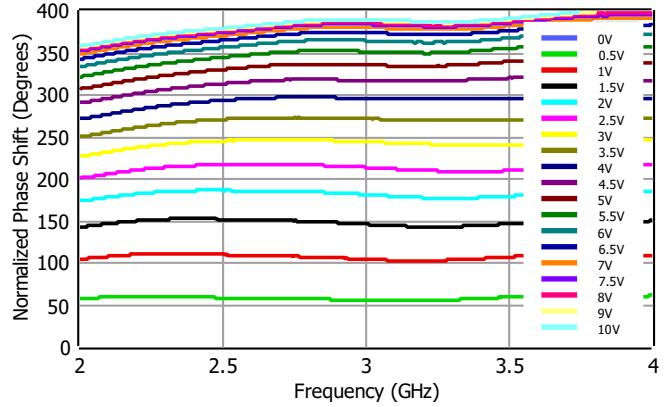

Input Return Loss

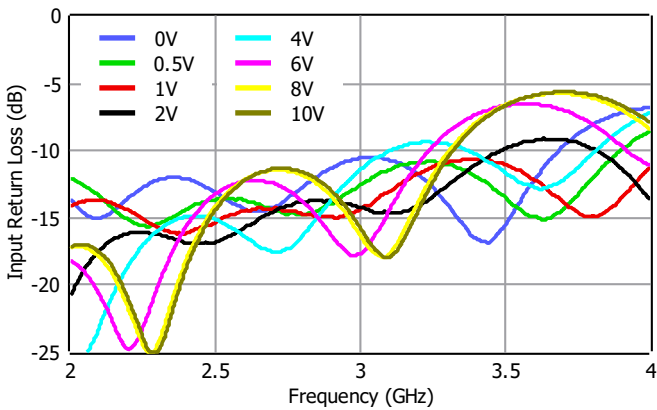

Output Return Loss

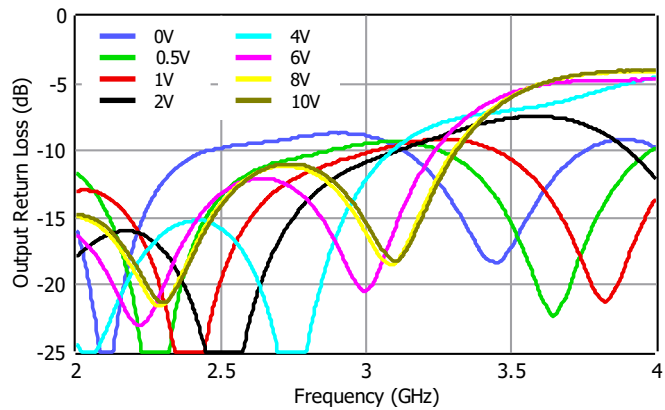

Input P1dB

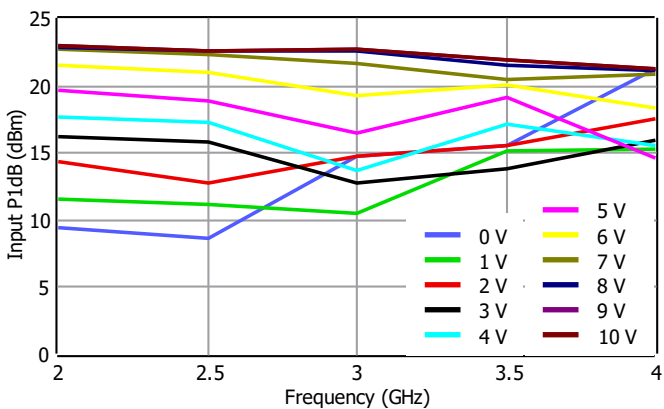

Input P1dB vs Control Voltages

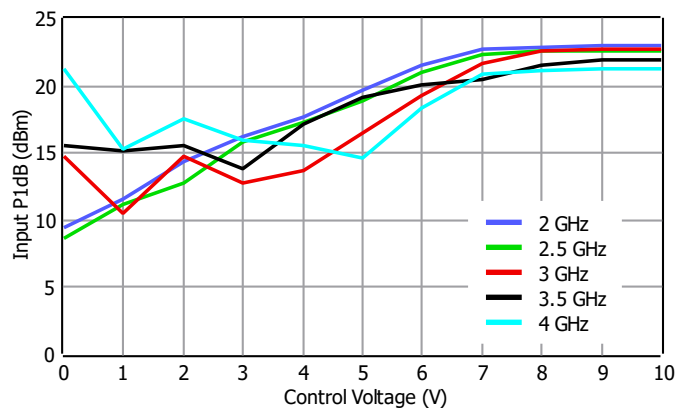

## Typical Performance Plots

### 2.4GHz Operation

Conditions unless otherwise specified: Typical, T = 25 C, CW.

Insertion Loss

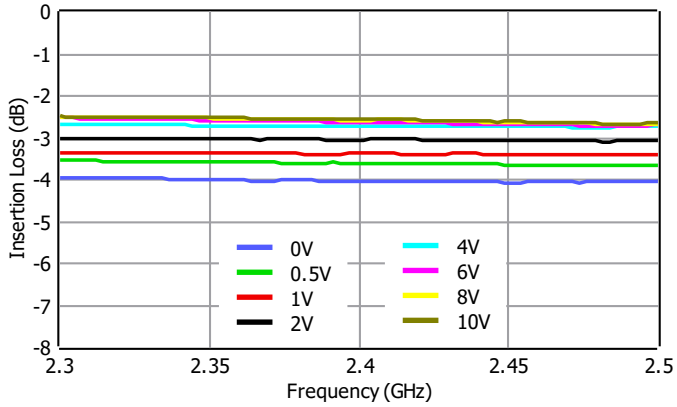

Insertion Loss vs Control Voltage at 2.4 GHz

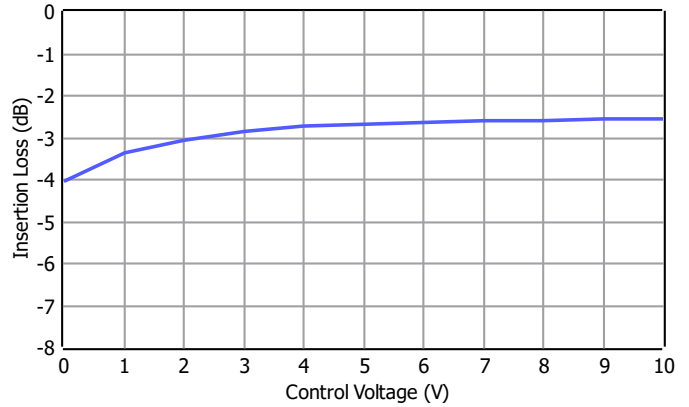

Normalized Phase Shift

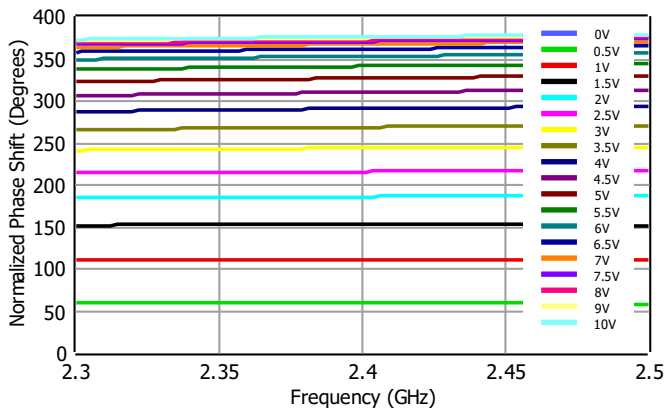

Normalized Phase Shift vs Control Voltage at 2.4 GHz

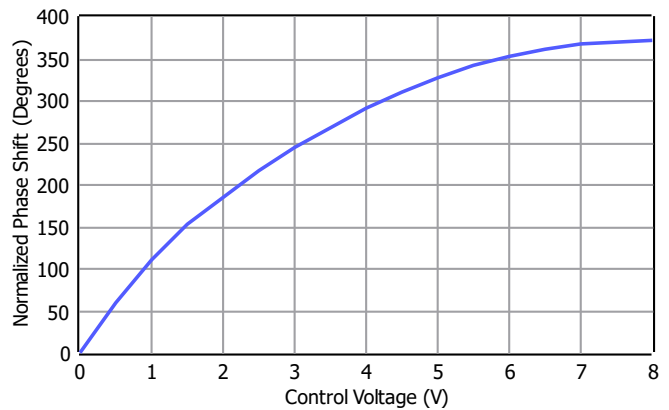

Input Return Loss

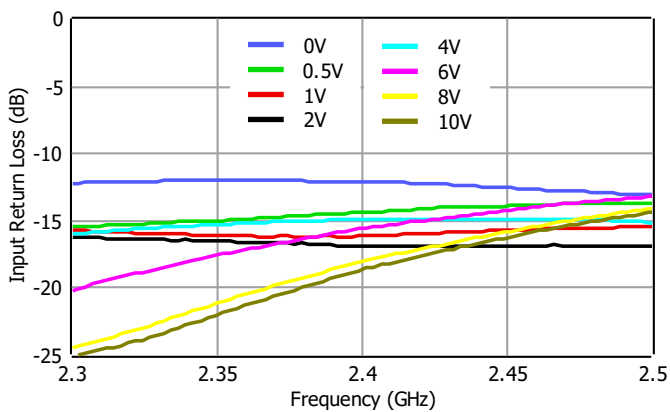

Output Return Loss

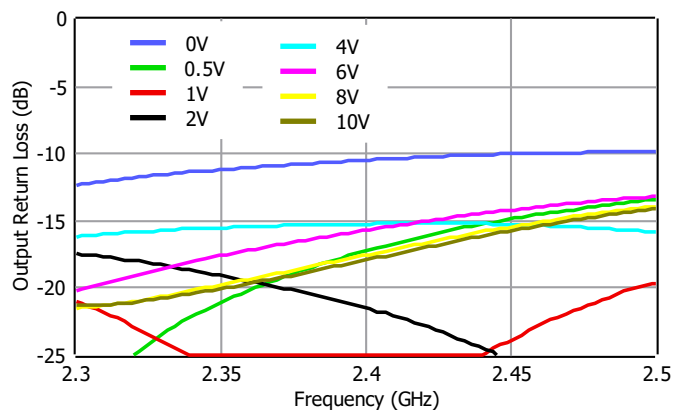

## Typical Performance Plots

Conditions unless otherwise specified: Typical, T = 25 C, CW.

Input P1dB vs Control Voltage at 2.4 GHz

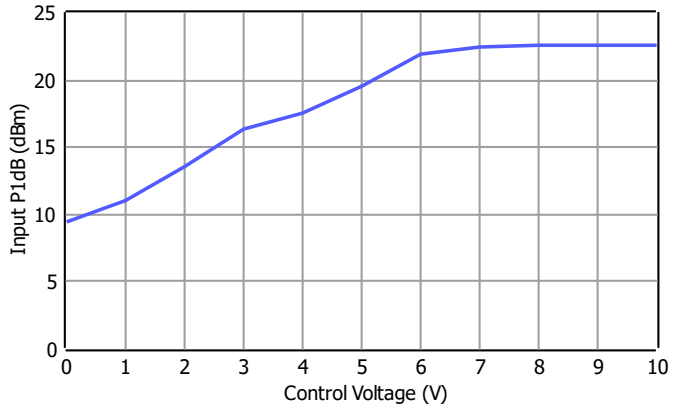

## Pin Description

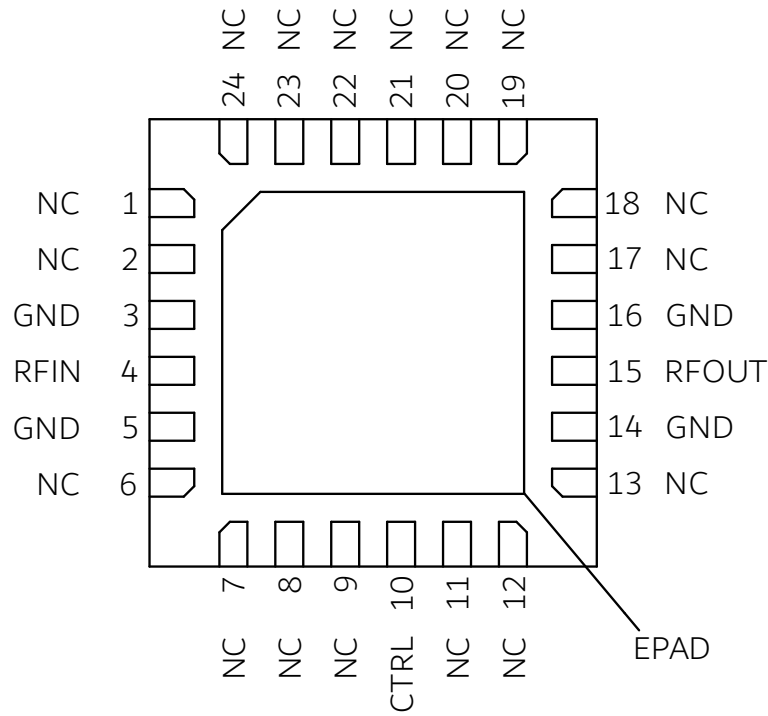

Pin Number	Pin Name	Description
4	RF IN	RF input pin. AC coupled.
15	RF OUT	RF output pin. AC coupled.
10	CTRL	Control voltage pin.
1, 2, 6-9, 11-13, 17-24	NC	These pins are not internally connected. Can be grounded on the PCB.
3, 5, 14, 16	GND	Ground.
25	EPAD	Exposed Pad on the bottom of the package should be connected to ground with multiple number of vias to reduce the inductance to the GND.

## Applications Information

Signal entering RF IN goes to RF OUT with a phase shift.

Typical application schematic to operate the phase shifter is given below.

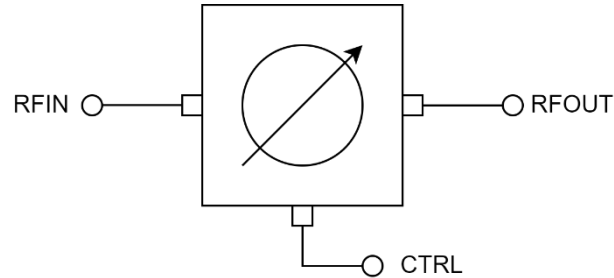

All data are generated with connectorized evaluation PCB measurements. Then the PCB trace and connector transition losses are de-embedded to generate the insertion loss data shown in this document.

The NC pins of the phase shifter are connected to the GND on the PCBs used to generate the plots shown in this document.

## Absolute Maximum Ratings

Parameter	Value/Range
Control Voltage (CTRL)	TBD
RF Input Power	TBD
Storage Temperature	-55 to +125°C

Operation of this device outside the parameter ranges given above may cause damage. These conditions should not be applied simultaneously.

## Mechanical and Marking Information

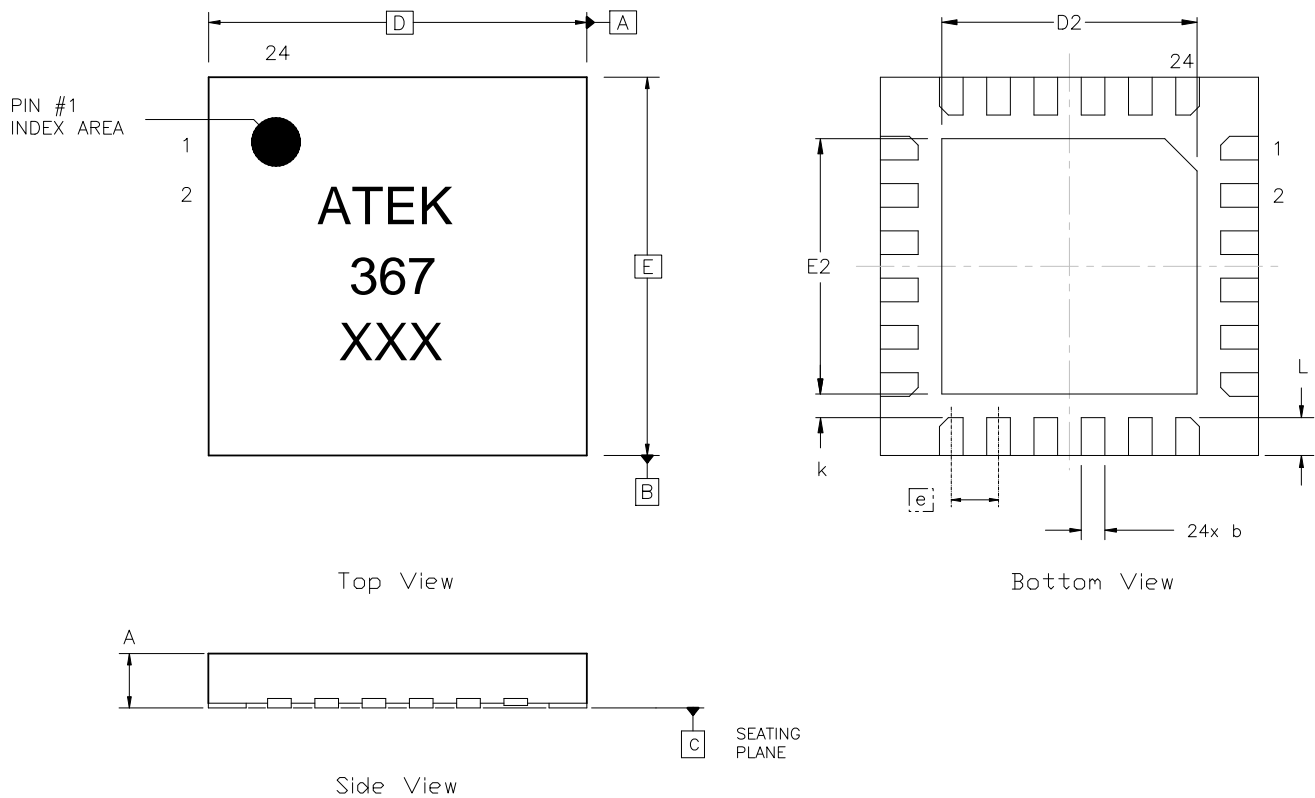

NOTES:  
1) ALL DIMENSIONS IN MM

SYMBOL	MIN	MAX	SYMBOL	MIN	MAX
A, $\varnothing$	0.80	1.00	E2	2.60	2.80
b	0.18	0.30	e	0.50	BSC
D	4.00	BSC	k	0.20	-
D2	2.60	2.80	L	0.35	0.45
E	4.00	BSC			

## Handling Precautions



Caution!  
ESD-Sensitive Device  
Handle Accordingly

## Contact Information

For the latest specifications, additional product information, support, and sales.

Web: [www.atekmidas.com](http://www.atekmidas.com)

Tel: +90-212-483-71-67

Email: [support@atekmidas.com](mailto:support@atekmidas.com)

## Notice

This document and its contents are property of ATEK MIDAS. ATEK MIDAS has the right to change the document at any time without notice. ATEK MIDAS distributes this document as a service to its customers. ATEK MIDAS supports its customers to help them create market leader products. Customer is responsible from choosing the product and the configuration the product. This document is provided `as is` and does not provide any warranty.

Customer is responsible for the usage of this document, the information provided in the document and the usage of products. ATEK MIDAS shall have no responsibility from the customer products, customer applications and doings of customers.

## Revisions

Revision No	Revision Date	Revision Reason	Section / Page No
1.0	21.02.2024	Initial Release	
1.1	22.02.2024	Plots Added	
1.2	22.02.2024	Formats and Content Fixed	
1.3	29.02.2024	Plots Added	