

Product Description

ATEK271 is a wideband absorptive SP4T switch with low loss and high isolation. Frequency of operation starts from low frequencies close to DC, goes up to 22 GHz.

RF input outputs are matched to 50 ohms internally.

Evaluation Board and bare die options are available upon request.

Product Features

- Frequency Range: LF - 22 GHz
- Insertion Loss: 1.7 dB
- Input IP3: 35 dBm
- Input P1dB: 23 dBm
- Single Supply

Applications

- Wideband Receivers
- Telecommunication
- Test and Measurement
- SATCOM
- SDR

Functional Block Diagram

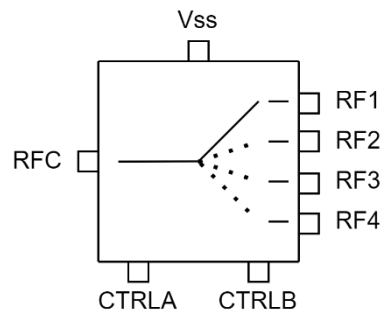

Electrical Specifications

Conditions unless otherwise specified: $V_{SS} = -5V$, Typical, $T = 25\text{ C}$, CW.

Parameter		Min	Typ	Max	Units
Operational Frequency Range		LF		22	GHz
Insertion Loss	4 GHz		1		dB
	8 GHz		1.4		
	12 GHz		1.8		
	16 GHz		2		
	20 GHz		2.2		
	22 GHz		2.6		
Isolation	4 GHz		48		dB
	8 GHz		49		
	12 GHz		35		
	16 GHz		34		
	20 GHz		44		
	22 GHz		50		
Input Return Loss			-16		dB
Output Return Loss			-20		dB
Input IP3			35		dBm
Input P1dB			23		dBm
Switching Speed	On		130		ns
50% Vctrl to 90% of RF Output	Off		20		
DC Supply Voltage (V_{SS})			-5		V
DC Supply Current (I_{SS})			3		mA
Control Supply Current (Total I_{ctrl})			0.5		mA
Control Voltage (CTRL)	Low	0			V
	High			-5	
Operating Temperature		-40		85	°C

Typical Performance Plots

Conditions unless otherwise specified: $V_{SS} = -5V$, Typical, $T = 25\text{ C}$, CW.

Insertion Loss

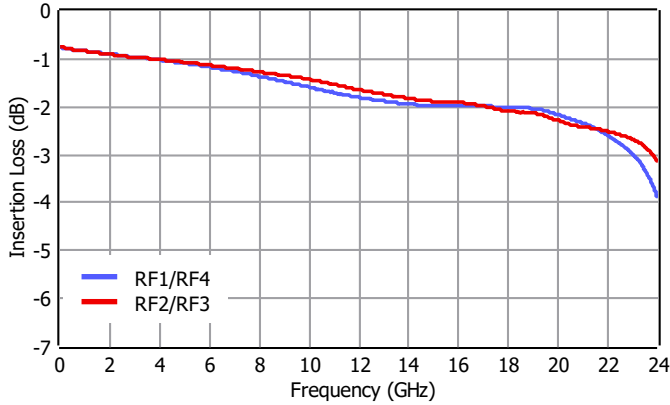

RF1/RF4 Return Loss

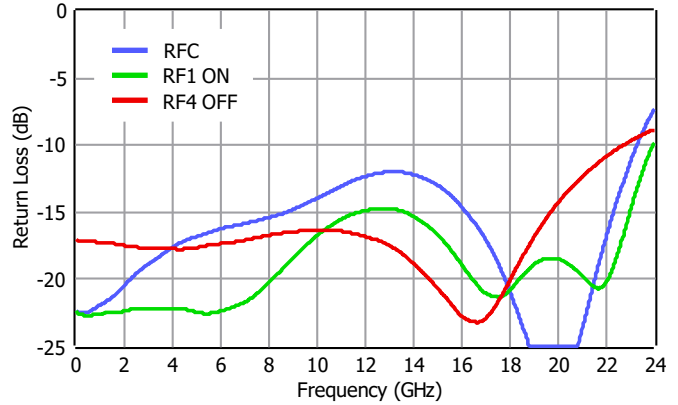

RF2/RF3 Return Loss

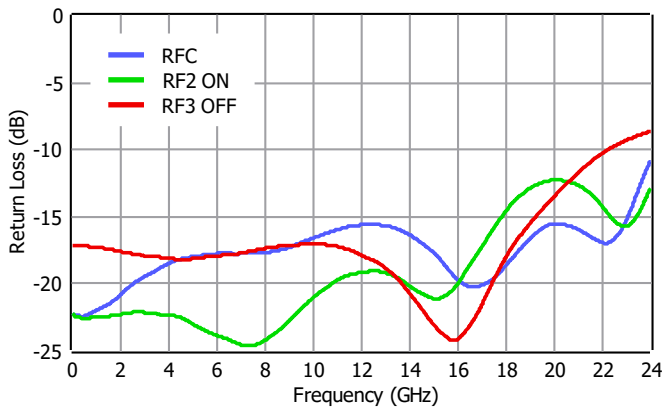

Isolation from RFC to RFx

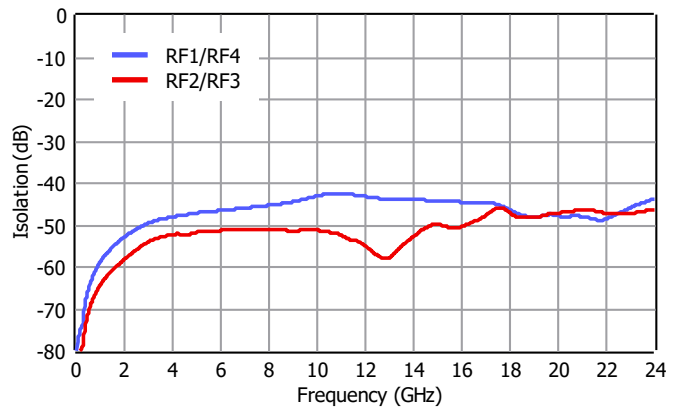

Typical Performance Plots

Conditions unless otherwise specified: $V_{SS} = -5V$, Typical, $T = 25\text{ C}$, CW.

Input P1dB at Low Frequency

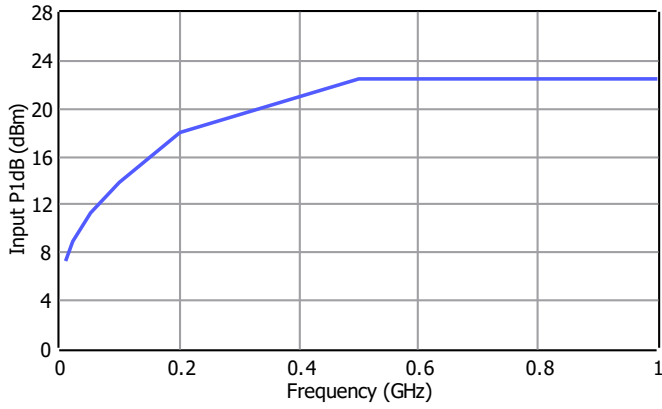

Input P1dB

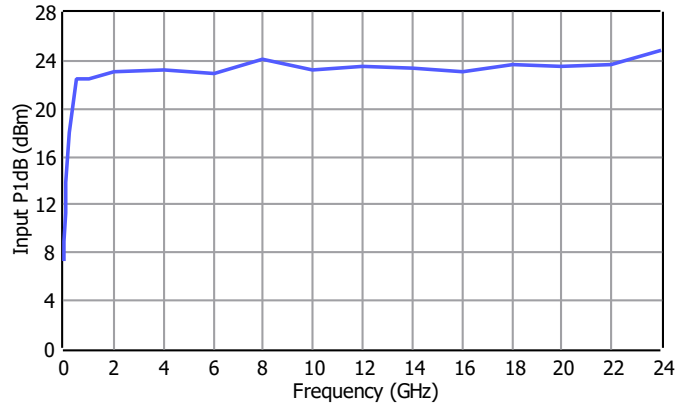

Input IP3 at Low Frequency

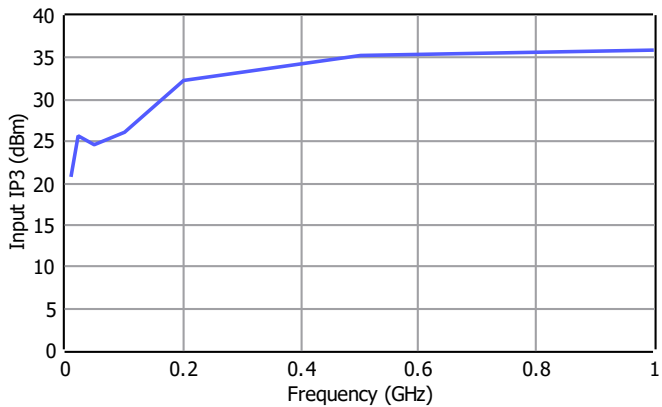

Input IP3

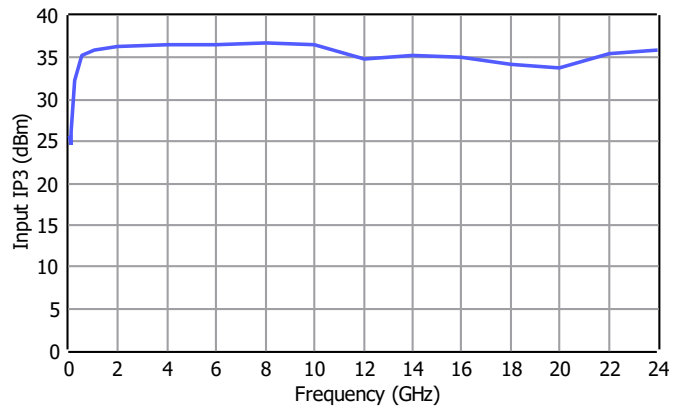

Pad Description and Mechanical Dimensions

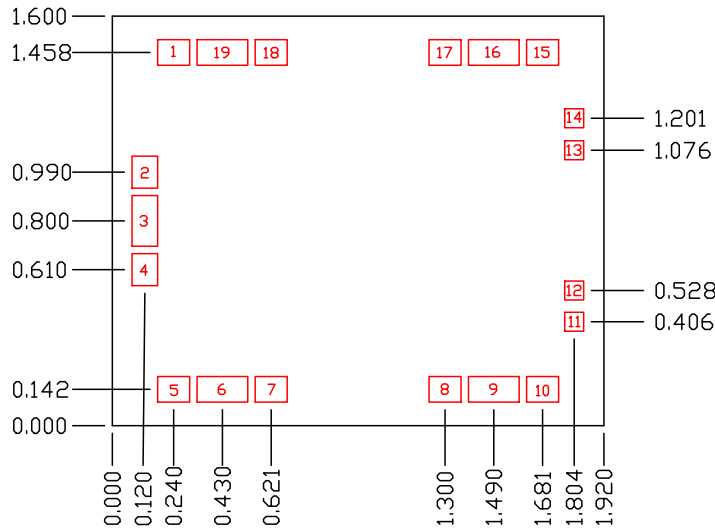

Units: millimeters
Thickness: 0.10
Die x, y size tolerance: ± 0.05
Backside of the die is ground

Pad Number	Pad Name	Pad Size (mm)	Description
3	RFC	0.100x0.200	RF input/output pad. If the DC voltage level on RF lines is not equal to 0 V, an external DC block capacitor is required.
19	RF1	0.200x0.100	RF input/output pad. If the DC voltage level on RF lines is not equal to 0 V, an external DC block capacitor is required.
16	RF2	0.200x0.100	RF input/output pad. If the DC voltage level on RF lines is not equal to 0 V, an external DC block capacitor is required.
9	RF3	0.200x0.100	RF input/output pad. If the DC voltage level on RF lines is not equal to 0 V, an external DC block capacitor is required.
6	RF4	0.200x0.100	RF input/output pad. If the DC voltage level on RF lines is not equal to 0 V, an external DC block capacitor is required.
11	VSS	0.075x0.075	Vss Bias Pad.
13	CTRLA	0.075x0.075	Control Pad.
12	CTRLB	0.075x0.075	Control Pad.
1, 5, 7, 8, 10, 15, 17, 18	GND	0.125x0.100	Ground.
2, 4	GND	0.100x0.125	Ground.
14	GND	0.075x0.075	Ground.
	Die Bottom		Ground.

Control Interface

CTRLA	CTRLB	RFC to State
HIGH	HIGH	RF1
HIGH	LOW	RF2
LOW	HIGH	RF3
LOW	LOW	RF4

Applications Information

Signal entering from RFC goes to RF1-RF4 depending on the switch state set by the user.

Vss bias is -5 V. Switch state can be set by switching control voltages between 0 V to -5 V.

Typical application schematic to operate the SP4T switch given below.

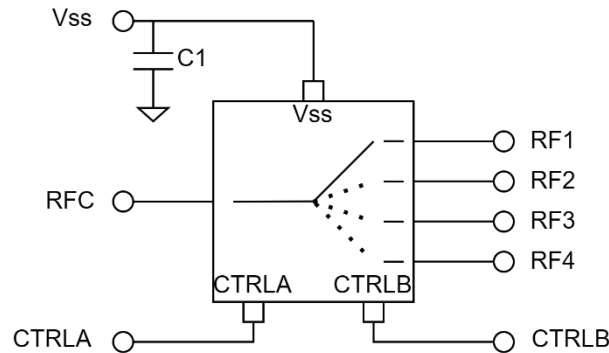

C1 is used to filter out the ripples and unwanted signals coming from the Vdd supply. Using additional capacitors in parallel to C1 will improve this filtering. If this filtering is of no concern, then SP4T can be operated without C1.

If needed, to filter out the ripples and unwanted signals on the external CTRL signals, a low pass filter in series R, shunt C configuration can be implemented on the CTRL lines. Note that external RC filtering limits the state switching speed of the SP4T.

CTRLA and CTRLB voltages are used for setting the switch state.

Defined voltages in specification table are valid when Vss supply and control voltages are equal such as $V_{ss} = V_{ctrls} = 5V$ or $V_{ss} = V_{ctrls} = 3.3V$.

Small signal data plots are gathered by chip on board probe PCB measurements to generate plots shown in this document.

Large signal datasheet plots are generated by chip on board connectorized evaluation boards (EVBs), PCB and connector losses are de-embedded.

Large signal data are generated with connectorized evaluation PCB measurements. Then the PCB trace and connector transition losses are de-embedded, to generate plots shown in this document.

NC pins of the SP4T are connected to the GND on the EVB used to generate the plots shown in this document.

Absolute Maximum Ratings

Parameter	Value/Range
Supply Voltage (V _{ss})	TBD
RF Input Power	TBD
Storage Temperature	-55 to +125°C

Operation of this device outside the parameter ranges given above may cause damage. These conditions should not be applied simultaneously.

Handling Precautions



Caution!
ESD-Sensitive Device
Handle Accordingly

Contact Information

For the latest specifications, additional product information, support, and sales.

Web: www.atekmidas.com

Tel: +90-212-483-71-67

Email: support@atekmidas.com

Notice

This document and its contents are property of ATEK MIDAS. ATEK MIDAS has the right to change the document at any time without notice. ATEK MIDAS distributes this document as a service to its customers. ATEK MIDAS supports its customers to help them create market leader products. Customer is responsible from choosing the product and the configuration the product. This document is provided `as is` and does not provide any warranty.

Customer is responsible for the usage of this document, the information provided in the document and the usage of products. ATEK MIDAS shall have no responsibility from the customer products, customer applications and doings of customers.

Revisions

Revision No	Revision Date	Revision Reason	Section / Page No
1.0	26.03.2025	Initial Release	