

Product Description

ATEK259P4 is a wideband reflective SP8T switch with low loss and high isolation. Frequency of operation starts from low frequencies close to DC, goes up to 12 GHz.

Operating with positive supply voltage and switch state is chosen by positive voltage control interface. Eliminates the need for external negative bias circuitry for the user.

RF input outputs are matched to 50 ohms internally. Switch is housed in a compact low cost 4x4 mm surface mount package.

Evaluation Board, bare die, custom package, and module options are available upon request.

Product Features

- Frequency Range: LF - 12 GHz
- Insertion Loss: 1.7 dB at 6 GHz
- Positive Supply
- Positive Control
- 4x4 mm compact size

Applications

- Wideband Receivers
- Telecommunication
- Test and Measurement
- SATCOM
- SDR

Functional Block Diagram

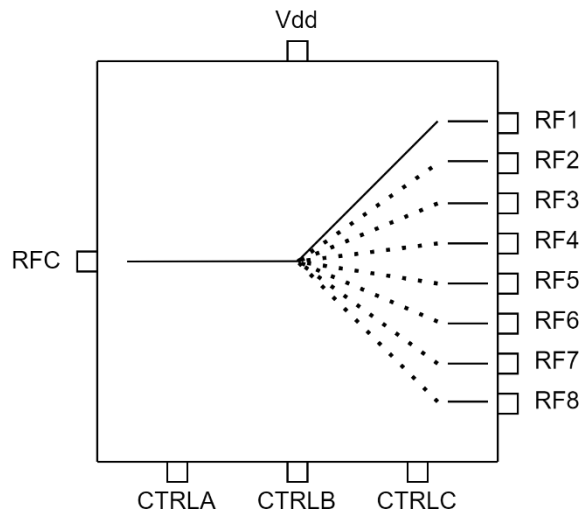

Electrical Specifications

Conditions unless otherwise specified: $V_{DD} = 5\text{ V}$, Typical, $T = 25\text{ C}$, CW.

Parameter		Min	Typ	Max	Units
Operational Frequency Range		LF		12	GHz
Insertion Loss	2 GHz		1.3		dB
	4 GHz		1.5		
	8 GHz		1.8		
	12 GHz		2.7		
Isolation	2 GHz		45		dB
	4 GHz		45		
	8 GHz		43		
	12 GHz		33		
Input Return Loss			-18		dB
Output Return Loss			-21		dB
Input P1dB			28		dBm
Input IP3			46		dBm
Switching Time	On		TBD		ns
	Off		TBD		
DC Supply Voltage (Vdd)			5		V
DC Supply Current			7.5		mA
Control Voltage (CTRL)	Low		0		V
	High		5		
Operating Temperature		-40		85	°C

Typical Performance Plots

Conditions unless otherwise specified: $V_{DD} = 5V$, Typical, $T = 25\text{ C}$, CW.

Insertion Loss

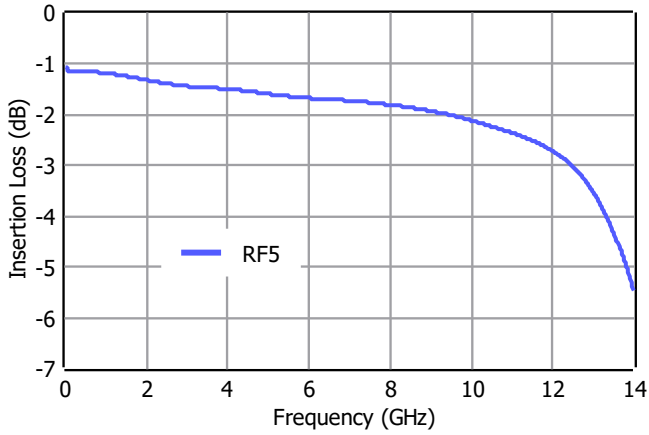

Insertion Loss

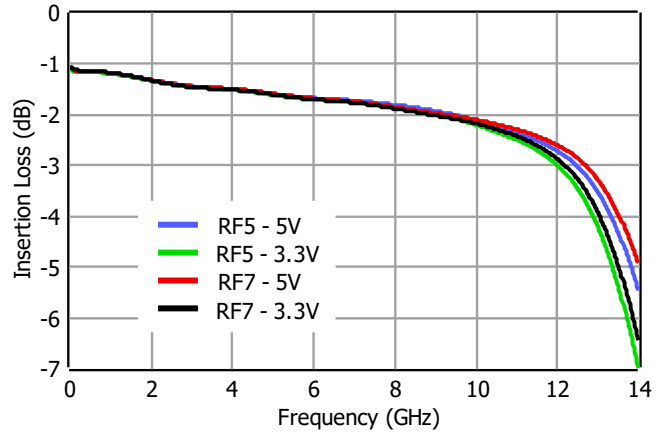

Return Loss at RF5 5V

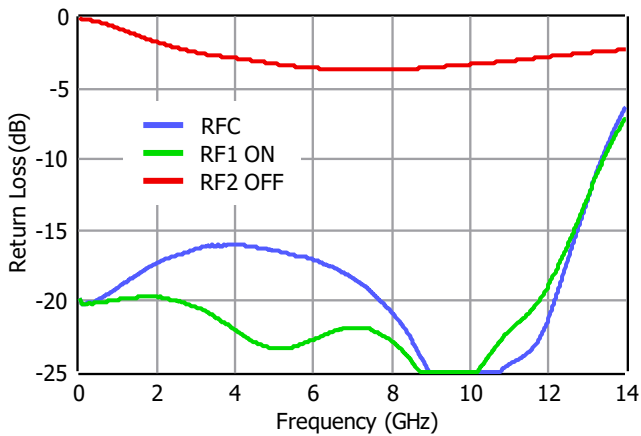

Return Loss at RF5 3.3V

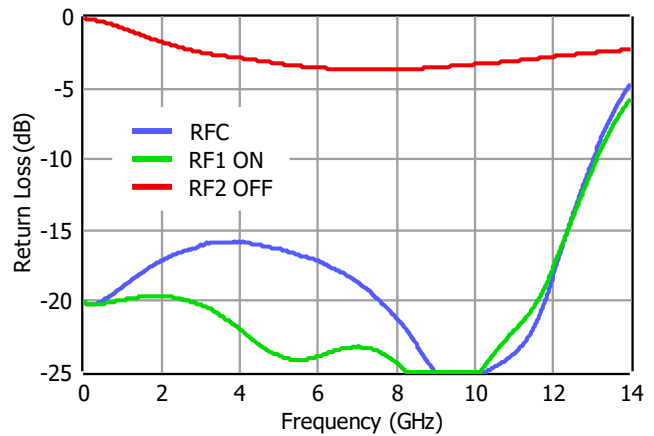

Return Loss at RF7 5V

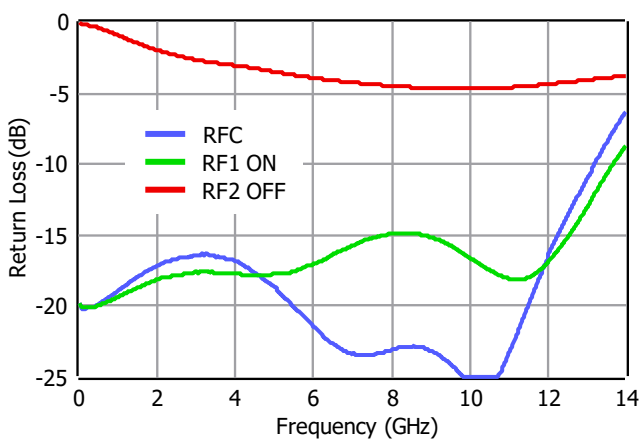

Return Loss at RF7 3.3V

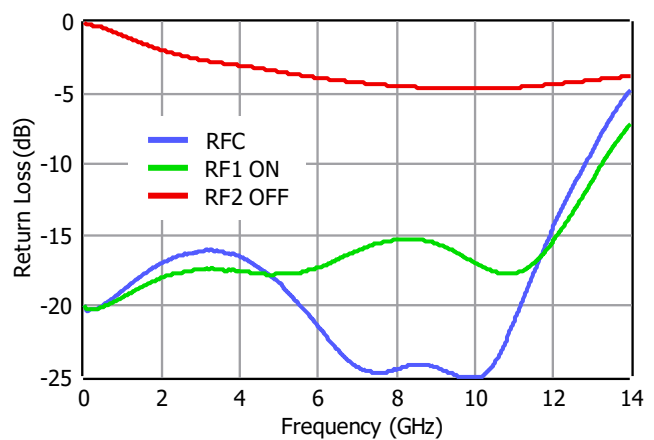

Typical Performance Plots

Conditions unless otherwise specified: $V_{DD} = 5V$, Typical, $T = 25\text{ C}$, CW.

Isolation

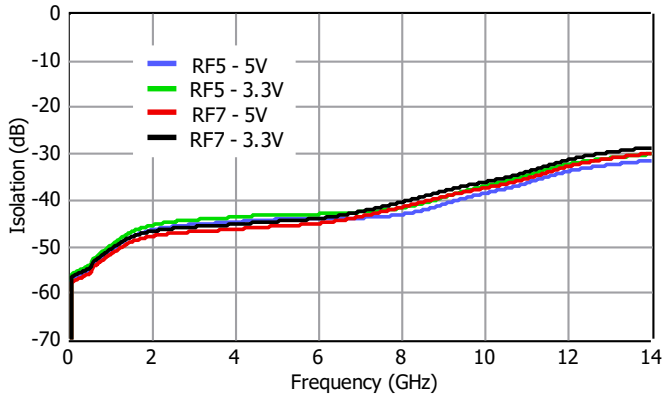

Input IP3

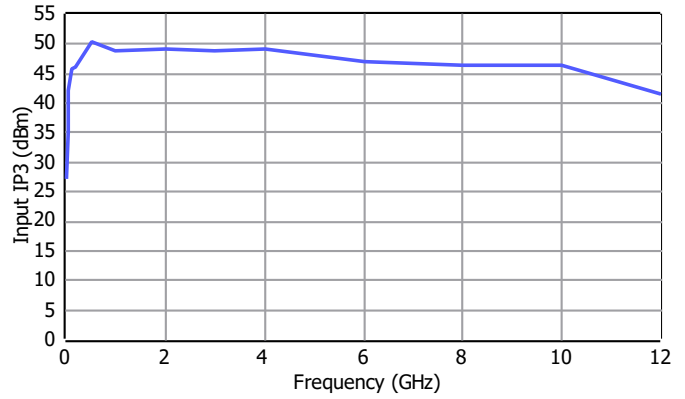

Input IP3 at Low Frequency

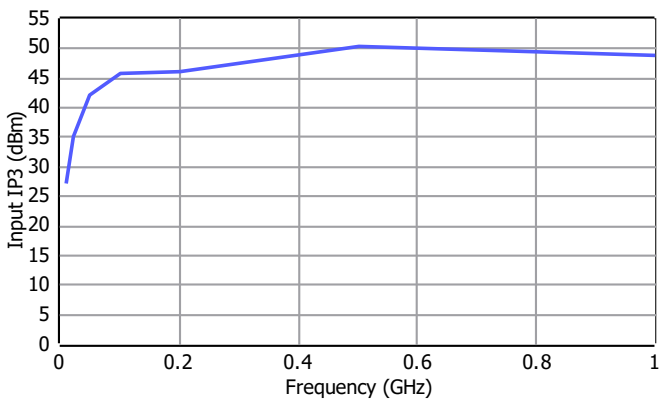

Input P1dB

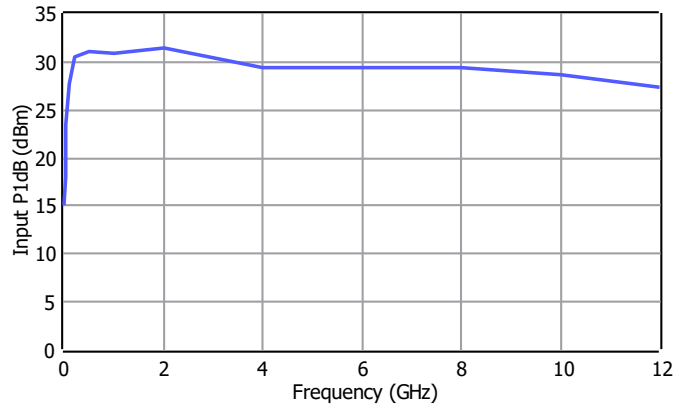

Input P1dB at Low Frequency

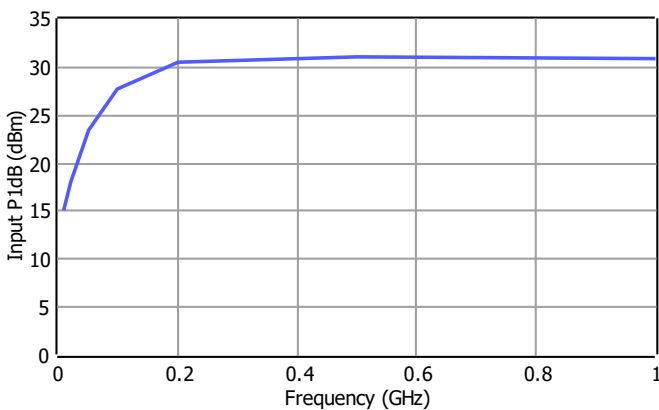

Pin Description

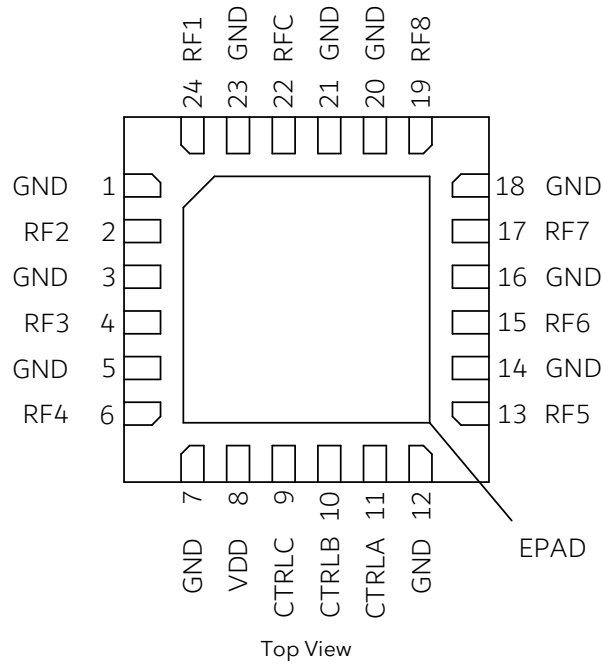

Pin Number	Pin Name	Description
22	RFC	RF input/output pin. Wideband DC block capacitor is required.
24	RF1	RF input/output pin. Wideband DC block capacitor is required.
2	RF2	RF input/output pin. Wideband DC block capacitor is required.
4	RF3	RF input/output pin. Wideband DC block capacitor is required.
6	RF4	RF input/output pin. Wideband DC block capacitor is required.
13	RF5	RF input/output pin. Wideband DC block capacitor is required.
15	RF6	RF input/output pin. Wideband DC block capacitor is required.
17	RF7	RF input/output pin. Wideband DC block capacitor is required.
19	RF8	RF input/output pin. Wideband DC block capacitor is required.
8	VDD	Vdd bias pin.
11	CTRLA	Control pin.
10	CTRLB	Control pin.
9	CTRLC	Control pin.
1, 3, 5, 7, 12, 14, 16, 18, 20, 21, 23	GND	Ground.
17	EPAD	Exposed Pad on the bottom of the package should be connected to ground with multiple number of vias to reduce the inductance to the GND.

Control Interface

CTRLA	CTRLB	CTRLC	RFC to State
LOW	LOW	LOW	RF1
LOW	LOW	HIGH	RF2
LOW	HIGH	LOW	RF3
LOW	HIGH	HIGH	RF4
HIGH	LOW	LOW	RF5
HIGH	LOW	HIGH	RF6
HIGH	HIGH	LOW	RF7
HIGH	HIGH	HIGH	RF8

Applications Information

Signal entering from RFC goes to RF1-8 depending on the switch state set by the user.

Vdd bias is 5 V and control voltages are CMOS compatible. Switch state can be set by switching control voltages between 0 V to 5 V. Operating the switch is done with positive voltage rails without the need for negative voltage levels.

Typical application schematic to operate the SP8T switch given below.

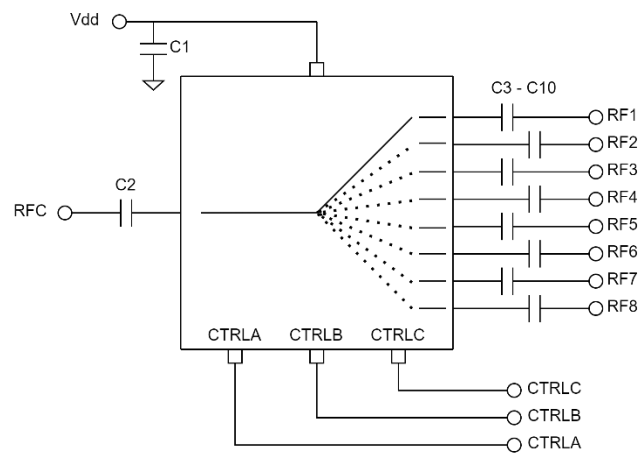

C1 is used to filter out the ripples and unwanted signals coming from the Vdd supply. Using additional capacitors in parallel to C1 will improve this filtering. If this filtering is of no concern, then SP8T can be operated without C1.

If needed, to filter out the ripples and unwanted signals on the external CTRL signals, a low pass filter in series R, shunt C configuration can be implemented on the CTRL lines. Note that external RC filtering limits the state switching speed of the SP4T.

CTRLA, CTRLB and CTRLC voltages are used for setting the switch state.

C2 to C10 are wideband DC block capacitors.

Large signal datasheet plots are generated by connectorized evaluation boards (EVBs), PCB and connector losses are de-embedded. Small signal plots are generated by probing the RF lines with RF probes to eliminate the connector transition effects.

NC pins of the SP8T are connected to the GND on the EVB used to generate the plots shown in this document.

Absolute Maximum Ratings

Parameter	Value/Range
Supply Voltage (Vdd)	TBD
RF Input Power	TBD
Storage Temperature	-55 to +125°C

Operation of this device outside the parameter ranges given above may cause damage. These conditions should not be applied simultaneously.

Mechanical and Marking Information

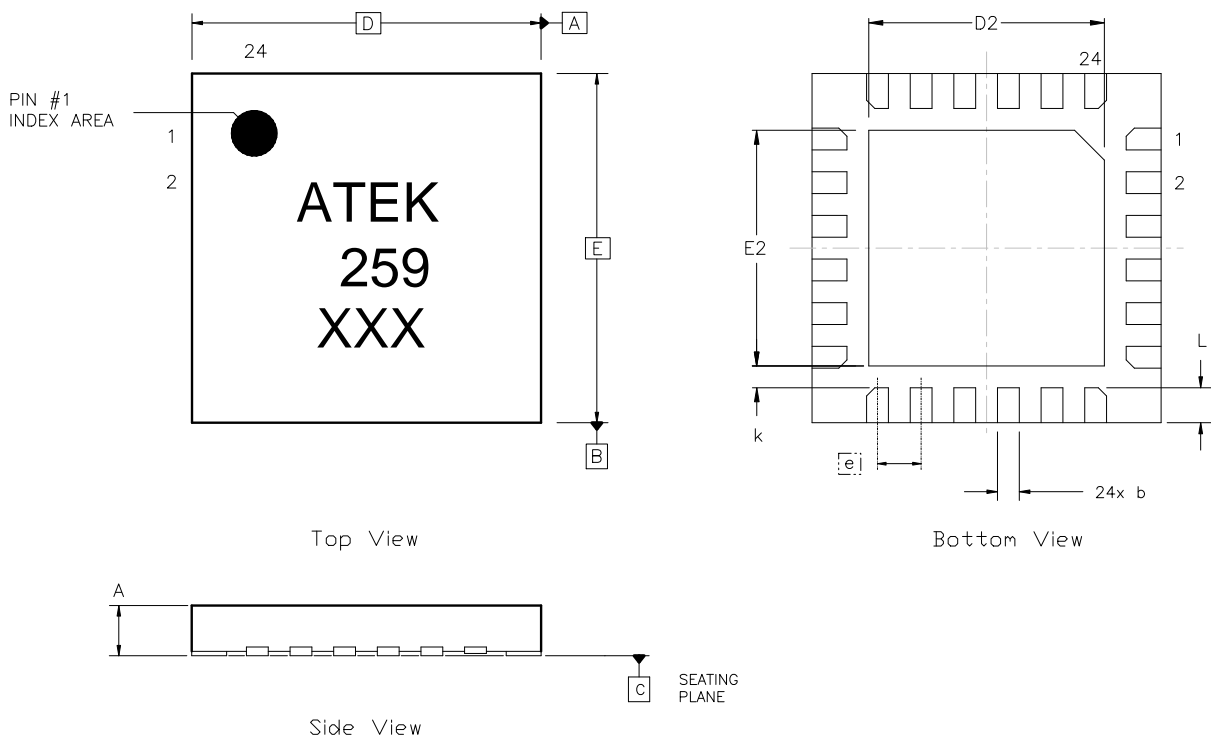

NOTES:
1) ALL DIMENSIONS IN MM

SYMBOL	MIN	MAX	SYMBOL	MIN	MAX
A, V	0.80	1.00	E2	2.60	2.80
b	0.18	0.30	e	0.50 BSC	
D	4.00 BSC		k	0.20	-
D2	2.60	2.80	L	0.35	0.45
E	4.00 BSC				

Handling Precautions



Caution!
ESD-Sensitive Device
Handle Accordingly

Contact Information

For the latest specifications, additional product information, support, and sales.

Web: www.atekmidas.com

Tel: +90-212-483-71-67

Email: support@atekmidas.com

Notice

This document and its contents are property of ATEK MIDAS. ATEK MIDAS has the right to change the document at any time without notice. ATEK MIDAS distributes this document as a service to its customers. ATEK MIDAS supports its customers to help them create market leader products. Customer is responsible from choosing the product and the configuration the product. This document is provided `as is` and does not provide any warranty.

Customer is responsible for the usage of this document, the information provided in the document and the usage of products. ATEK MIDAS shall have no responsibility from the customer products, customer applications and doings of customers.

Revisions

Revision No	Revision Date	Revision Reason	Section / Page No
1.0	30.05.2022	Initial Release	
1.1	26.10.2022	Format and Content Fixed	
1.2	06.03.2023	Plots Added	
1.3	07.09.2023	Plots Added	