

## Product Description

ATEK175BP3 is a wideband low noise amplifier covering 0.01 to 3 GHz frequency range. Amplifier operational low frequency range can be extended to lower frequencies by increasing external component values.

ATEK175BP3 provides flat gain and sub-1dB noise figure over wide bandwidth without the need for external matching components. This allows users to easily realize wideband receiver frontends.

Amplifier housed in compact 3x3 mm low cost SMD package, input and output matched to 50 ohms internally. Evaluation Board, bare die, custom package, and module options are available upon request.

## Product Features

- Frequency Range: LF - 3 GHz
- Gain: 22 dB
- Noise Figure: 0.7 dB
- P1dB: 20 dBm
- Single Supply
- 3x3 mm compact size

## Applications

- Wideband Receivers
- Telecommunication
- Test and Measurement
- SATCOM
- SDR

## Functional Block Diagram

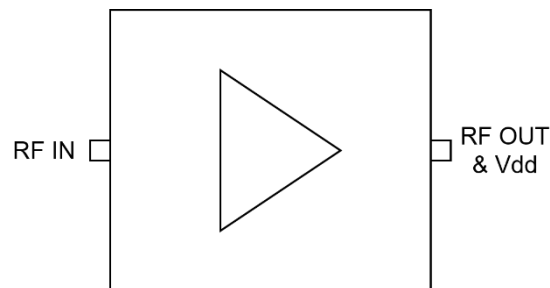

## Electrical Specifications

Conditions unless otherwise specified:  $V_{DD} = 5\text{ V}$ , Typical,  $T = 25\text{ C}$ , CW.

Parameter		Min	Typ		Max	Units
Operational Frequency Range		0.01			3	GHz
Gain	0.01 GHz		22.7			dB
	0.5 GHz		23			
	1 GHz		22.8			
	2 GHz		22.2			
	3 GHz		21.9			
Noise Figure $V_{DD} = 3.3\text{ V}$	0.01 GHz		0.7			dB
	0.5 GHz		0.2			
	1 GHz		0.7			
	2 GHz		0.9			
	3 GHz		1.1			
Input Return Loss			-10			dB
Output Return Loss			-12			dB
Output IP3			32			dBm
Output P1dB			20			dBm
Psat			21			dBm
DC Supply Voltage (Vdd)			3.3	5		V
DC Supply Current			26	58		mA
Operating Temperature		-40			85	°C

## Typical Performance Plots

Conditions unless otherwise specified:  $V_{DD} = 5V$ , Typical,  $T = 25\text{ C}$ , CW.

Gain

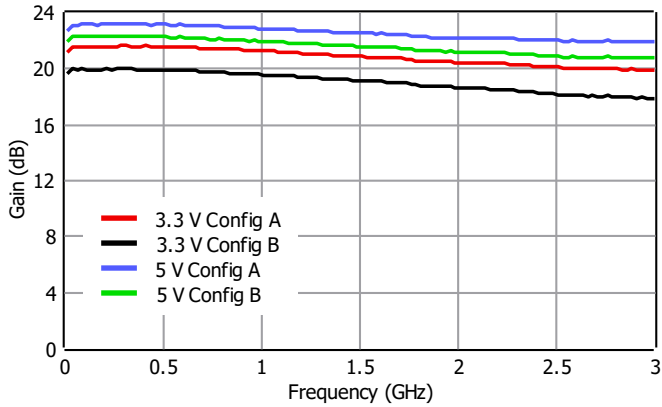

Gain - Low Frequency

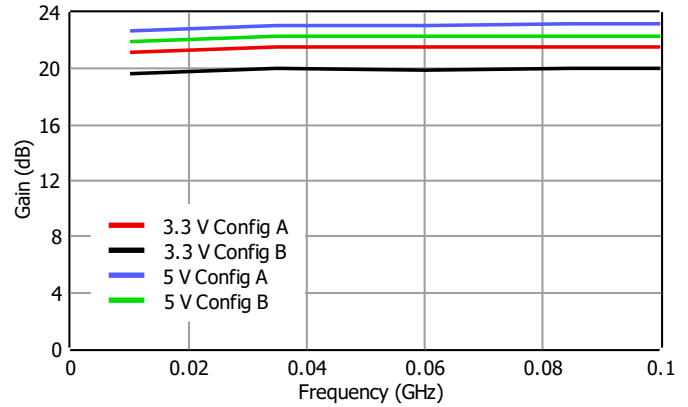

Input Return Loss

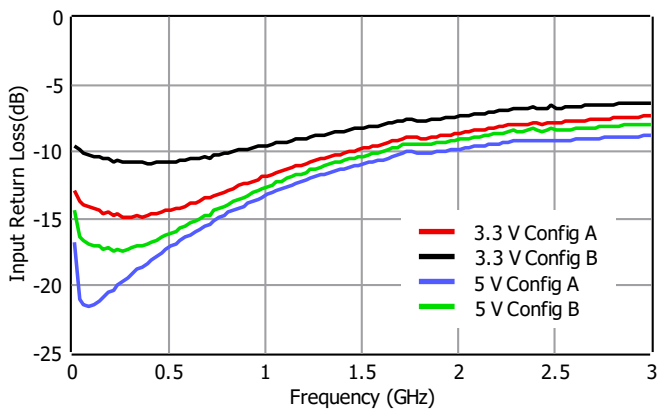

Output Return Loss

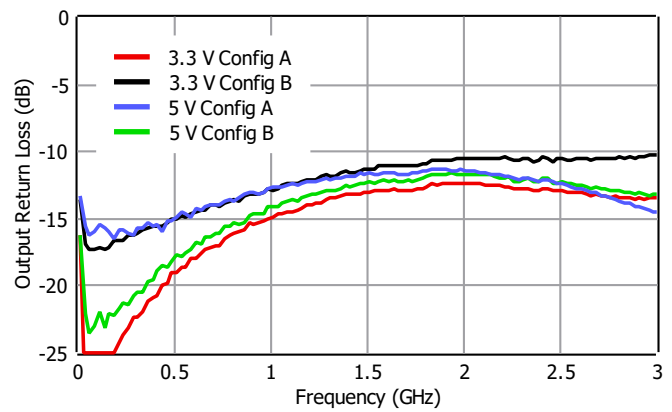

Isolation

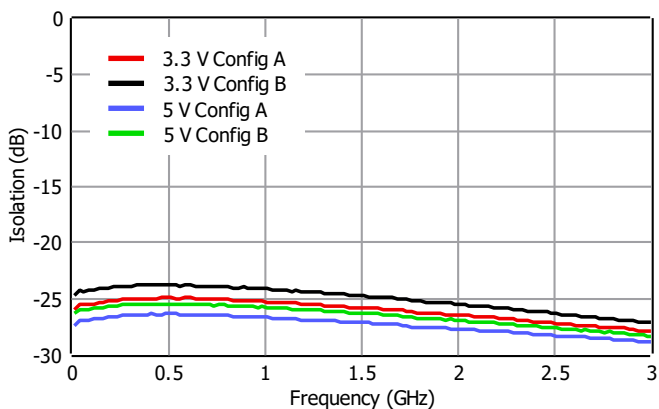

## Typical Performance Plots

Conditions unless otherwise specified:  $V_{DD} = 5\text{ V}$ , Typical,  $T = 25\text{ C}$ , CW.

Noise Figure

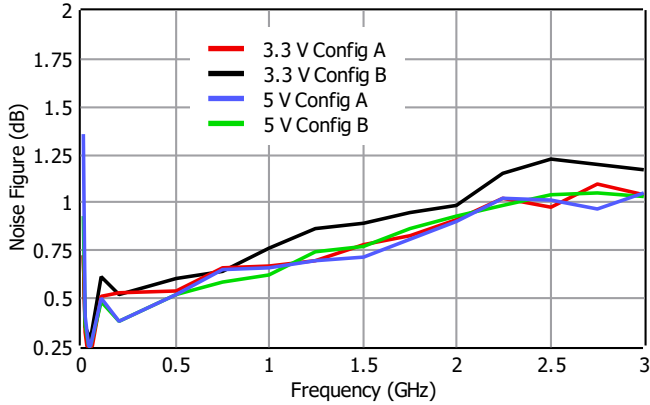

Noise Figure - Low Frequency

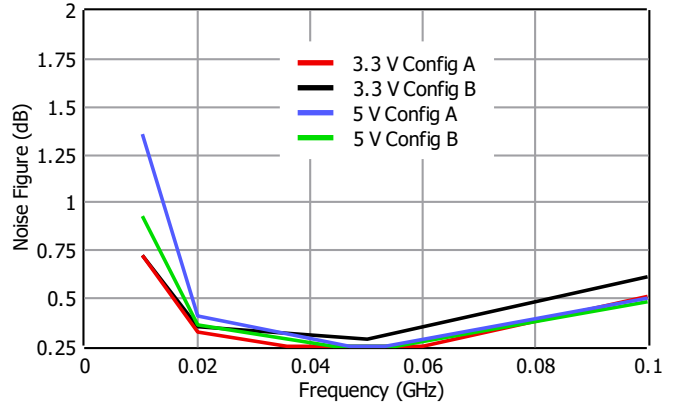

IP3

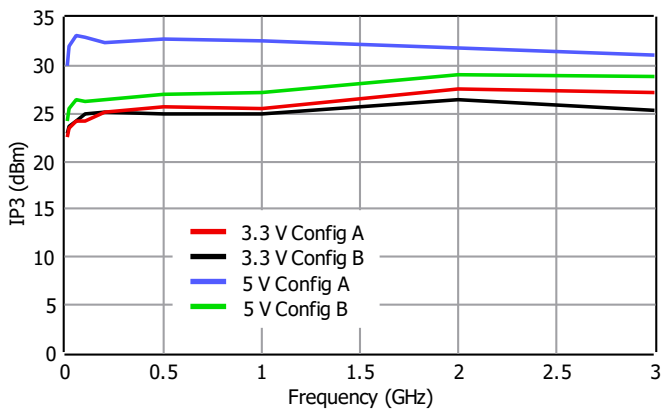

IP3 - Low Frequency

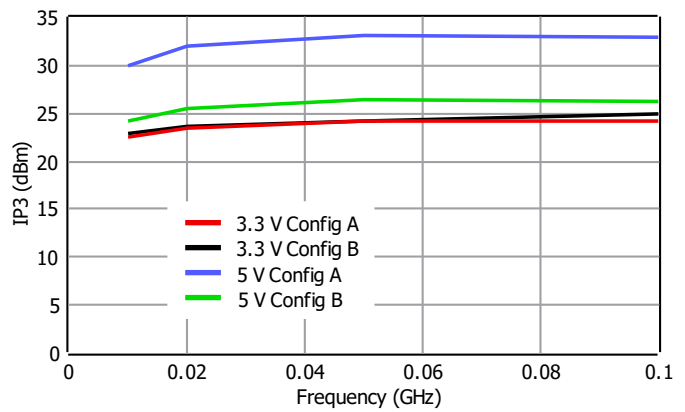

P1dB

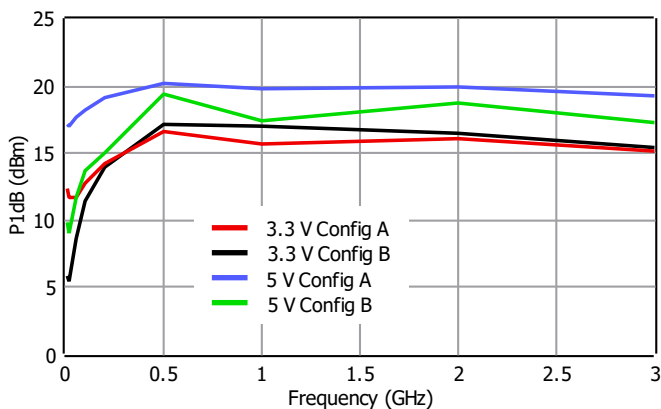

P1dB - Low Frequency

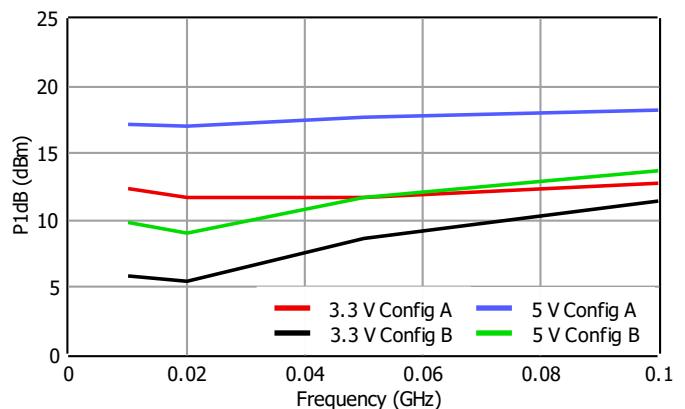

### Typical Performance Plots

Conditions unless otherwise specified:  $V_{DD} = 5V$ , Typical,  $T = 25\text{ C}$ , CW.

Psat

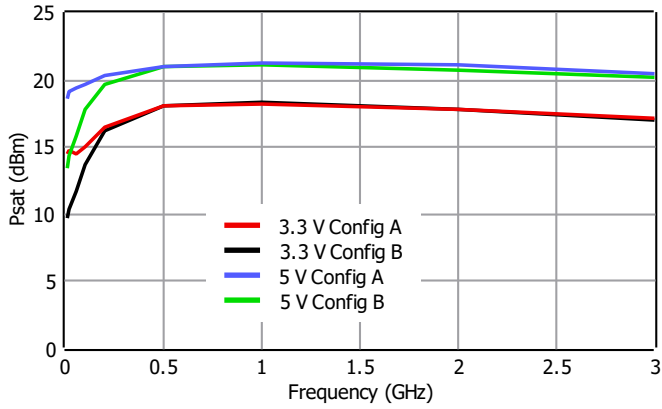

Psat - Low Frequency

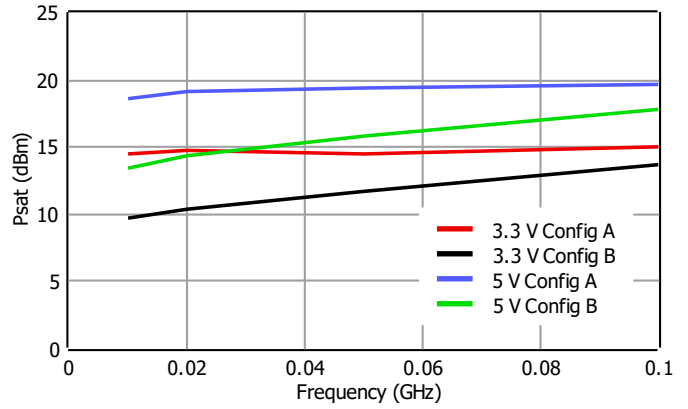

Pout vs Current, Frequency

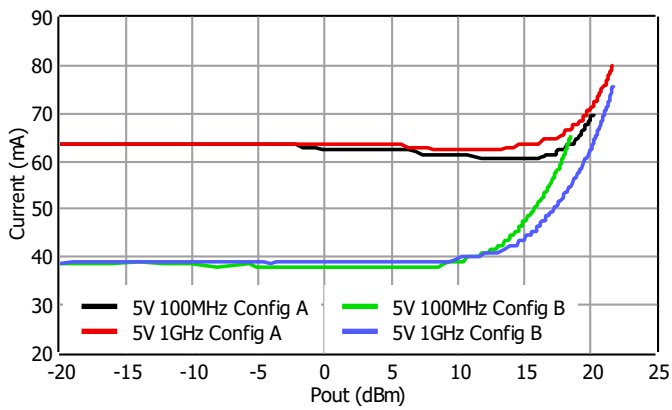

**Pin Description**

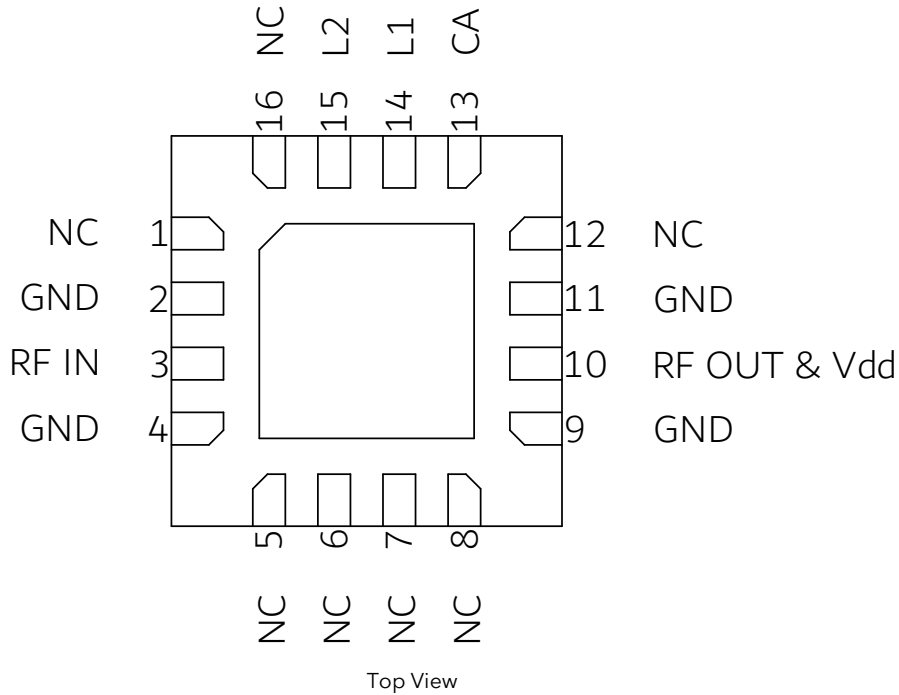

Pin Number	Pin Name	Description
3	RF IN	RF input pin. Wideband external DC block capacitor is required.
10	RF OUT & Vdd	RF output pin. Wideband external DC block capacitor is required.
13	CA	Current consumption adjustment pin. See Application Section for details.
14	L1	External inductor connection.
15	L2	External inductor connection.
1, 5-8, 12, 16	NC	These pins are not internally connected. Can be grounded on the PCB.
2, 4, 9, 11	GND	Ground.
17	EPAD	Exposed Pad on the bottom of the package should be connected to ground with multiple number of vias to reduce the inductance to the GND.

## Applications Information

Signal entering from RF IN goes to RF OUT with an amplification.  
Typical application schematic to operate the amplifier is given below.

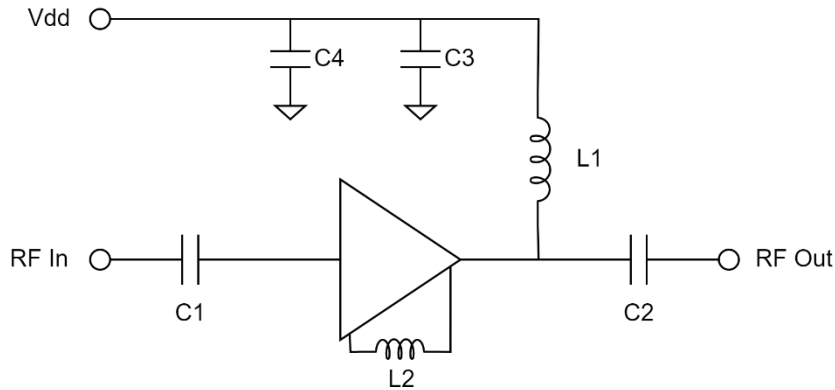

C1 and C2 are DC block capacitors. It is recommended to use wideband low loss DC block capacitors to achieve the best performance. Using low profile capacitors is also possible, which will result in additional loss.

L1 is used as RF choke inductor. It is recommended to use wideband RF choke to achieve wideband performance.

Choosing higher values for C1, C2 and L1 will allow amplifier to operate at lower frequencies, compared to the plots that is given in this datasheet. By increasing values of these components, low frequency operation can be extended below 10 MHz, at the expense of flat wideband, and high frequency response.

C3 and C4 are used to filter out the ripples and unwanted signals coming from the Vdd supply. Using additional capacitors in parallel to C3 and C4 will improve this filtering. If this filtering is of no concern, then amplifier can be operated without C3 and C4.

L2 inductor is wideband RF choke type inductor.

The amplifier has two configurations of operation. Leaving CA pin floating or connecting to ground sets the configuration state. By changing the configuration amplifier can provide higher P1dB at the expense of current consumption.

Configuration details for these pins are shown in the table below.

Configuration	CA State	Voltage (V)	Typical Current (mA)
A	Open/floating	3.3	26
		5	58
B	Short to GND	3.3	17
		5	36

Small signal plots are gathered with connectorized evaluation PCB measurements, to generate data shown in this document. Noise figure and large signal data are generated with connectorized evaluation PCB measurements. Then the input loss of the PCB is de-embedded from measurement data across frequency, to generate data shown in this document.

The NC pins of the Amplifier are connected to the GND on the PCBs used to generate the plots shown in this document.

Vdd values shown on the datasheet correspond the Vdd pins shown on the application schematic, not the Vdd pin of the amplifier. Vdd value can be increased to get higher P1dB performance.

## Absolute Maximum Ratings

Parameter	Value/Range
Supply Voltage (Vdd)	TBD
RF Input Power	TBD
Storage Temperature	-55 to +125°C

Operation of this device outside the parameter ranges given above may cause damage. These conditions should not be applied simultaneously.

## Mechanical and Marking Information

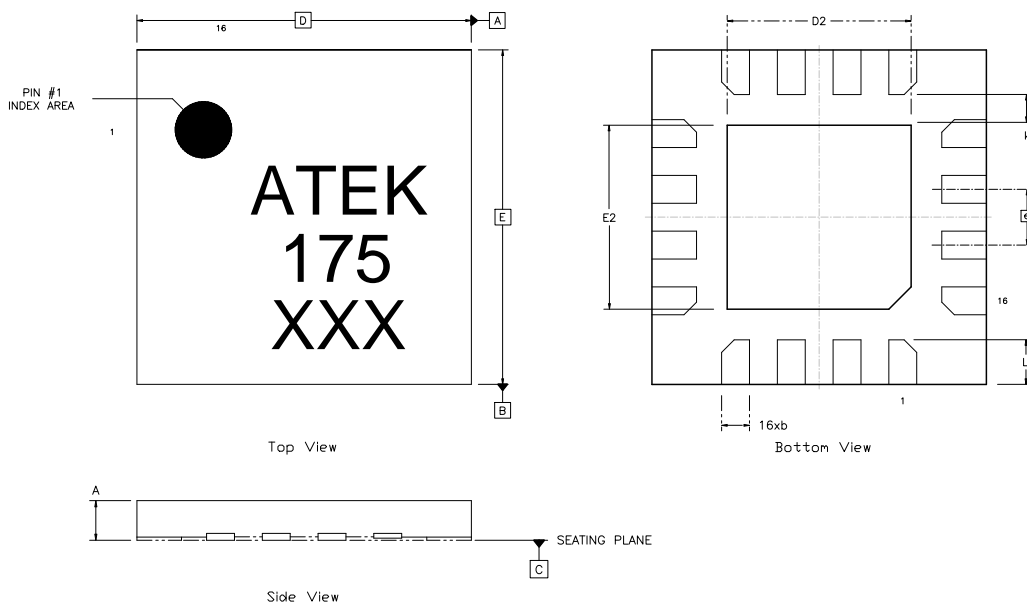

NOTES:  
1) ALL DIMENSIONS IN MM

SYMBOL	MIN	MAX	SYMBOL	MIN	MAX
A, V	0.80	1.00	E2	1.55	1.75
b	0.18	0.30	e	0.50	BSC
D	3.00	BSC	k	0.20	-
D2	1.55	1.75	L	0.35	0.45
E	3.00	BSC			

## Handling Precautions



Caution!  
ESD-Sensitive Device  
Handle Accordingly

## Contact Information

For the latest specifications, additional product information, support, and sales.

Web: [www.atekmidas.com](http://www.atekmidas.com)

Tel: +90-212-483-71-67

Email: [support@atekmidas.com](mailto:support@atekmidas.com)

## Notice

This document and its contents are property of ATEK MIDAS. ATEK MIDAS has the right to change the document at any time without notice. ATEK MIDAS distributes this document as a service to its customers. ATEK MIDAS supports its customers to help them create market leader products. Customer is responsible from choosing the product and the configuration the product. This document is provided `as is` and does not provide any warranty.

Customer is responsible for the usage of this document, the information provided in the document and the usage of products. ATEK MIDAS shall have no responsibility from the customer products, customer applications and doings of customers.

## Revisions

Revision No	Revision Date	Revision Reason	Section / Page No
1.0	21.10.2024	Initial Release	