

## Product Description

ATEK161 is a wideband low noise amplifier covering 1 to 26 GHz frequency range. Amplifier can be used up to 32 GHz.

ATEK161 provides flat gain and low noise over wideband with single supply voltage. This allows users to easily realize wideband receiver frontends.

RF input and output matched to 50 ohms internally.

Evaluation Board and bare die options are available upon request.

## Product Features

- Frequency Range: 1 - 26 GHz
- Gain: 15.5 dB
- Noise Figure: 1.8 dB at 10 GHz
- P1dB: 15 dBm
- Single Supply
- Positive Supply

## Applications

- Wideband Receivers
- Telecommunication
- Test and Measurement
- SATCOM
- SDR

## Functional Block Diagram

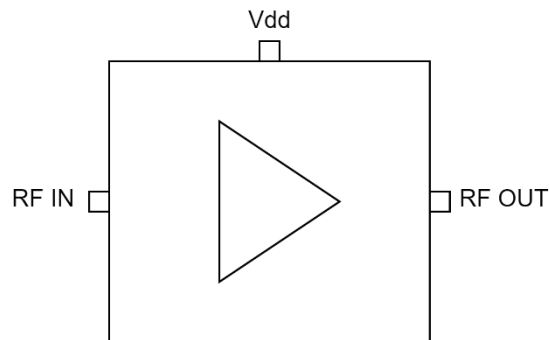

## Electrical Specifications

Conditions unless otherwise specified:  $V_{DD} = 5V$ , Typical,  $T = 25\text{ C}$ , CW.

| Parameter                   |        | Min | Typ  | Max | Units |
|-----------------------------|--------|-----|------|-----|-------|
| Operational Frequency Range |        | 1   |      | 32  | GHz   |
| Gain                        | 1 GHz  |     | 14.5 |     | dB    |
|                             | 4 GHz  |     | 16   |     |       |
|                             | 12 GHz |     | 15.4 |     |       |
|                             | 18 GHz |     | 15.5 |     |       |
|                             | 26 GHz |     | 15.8 |     |       |
| Noise Figure                | 1 GHz  |     | 4.2  |     | dB    |
|                             | 4 GHz  |     | 3.2  |     |       |
|                             | 12 GHz |     | 1.7  |     |       |
|                             | 18 GHz |     | 2.4  |     |       |
|                             | 26 GHz |     | 3.3  |     |       |
| Isolation                   | 1 GHz  |     | 53   |     | dB    |
|                             | 4 GHz  |     | 50   |     |       |
|                             | 12 GHz |     | 31   |     |       |
|                             | 18 GHz |     | 29   |     |       |
|                             | 26 GHz |     | 26   |     |       |
| Input Return Loss           |        |     | -19  |     | dB    |
| Output Return Loss          |        |     | -16  |     | dB    |
| Output IP3                  |        |     | TBD  |     | dBm   |
| Output P1dB                 |        |     | 15   |     | dBm   |
| Psat                        |        |     | TBD  |     | dBm   |
| DC Supply Voltage (Vdd)     |        |     | 5    |     | V     |
| DC Supply Current           |        |     | 55   |     | mA    |
| Operating Temperature       |        | -40 |      | 85  | °C    |

## Typical Performance Plots

Conditions unless otherwise specified:  $V_{DD} = 5\text{ V}$ , Typical,  $T = 25\text{ C}$ , CW.

Gain

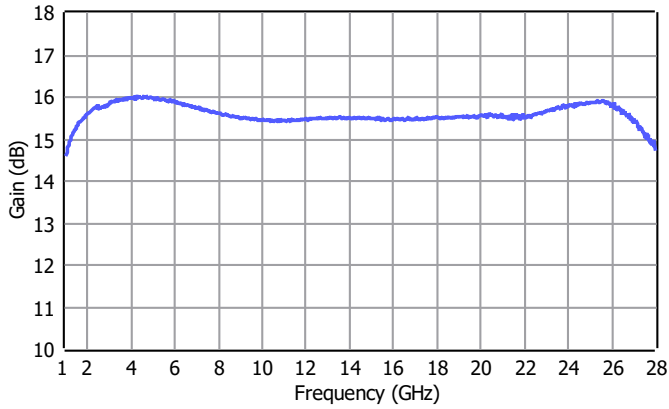

Gain Wideband

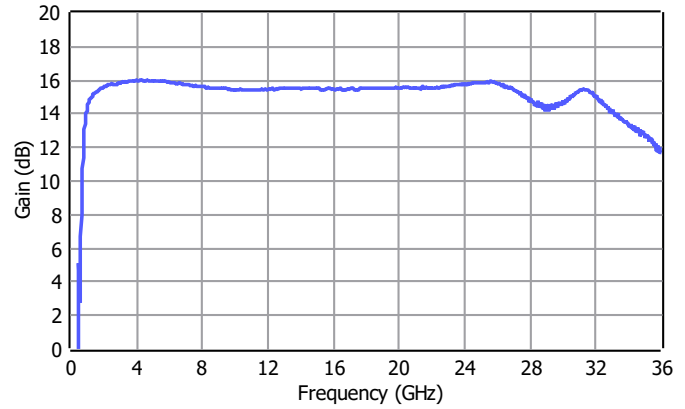

Input Return Loss

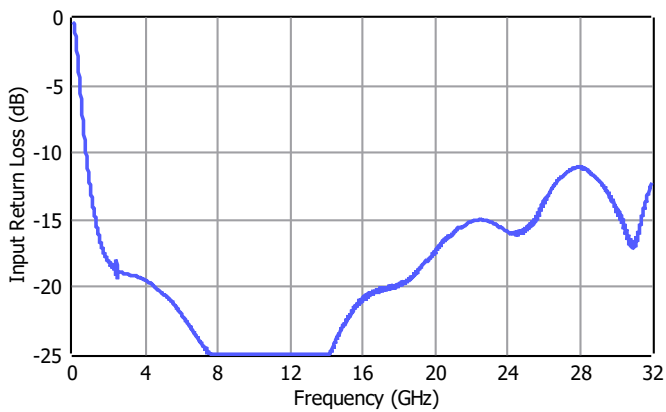

Output Return Loss

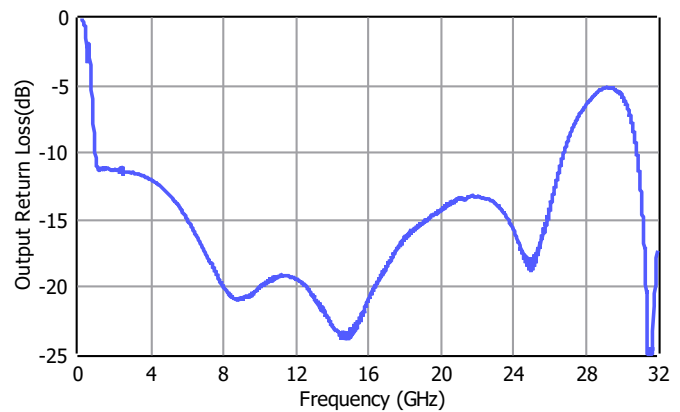

Isolation

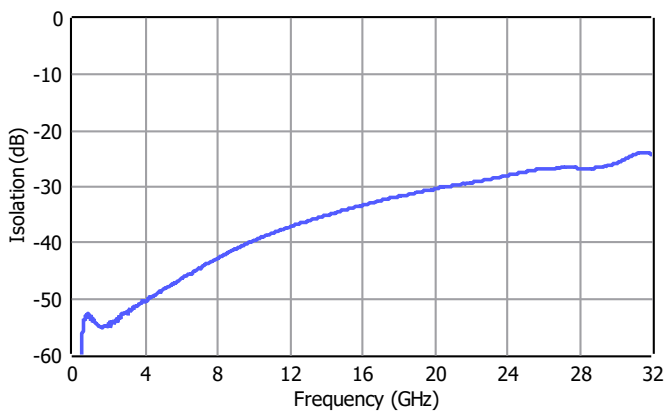

Noise Figure

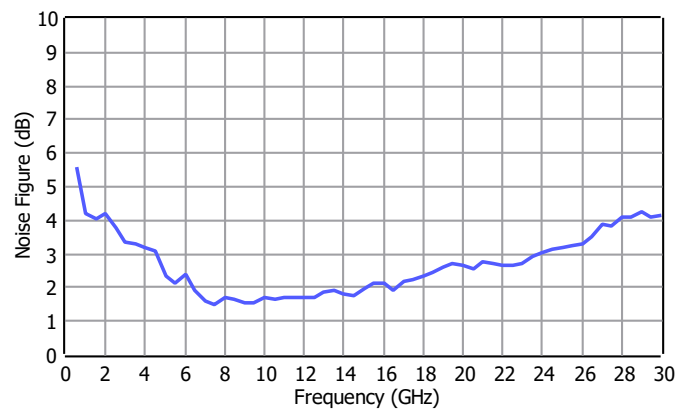

## Typical Performance Plots

Conditions unless otherwise specified:  $V_{DD} = 5V$ , Typical,  $T = 25\text{ C}$ , CW.

P1dB

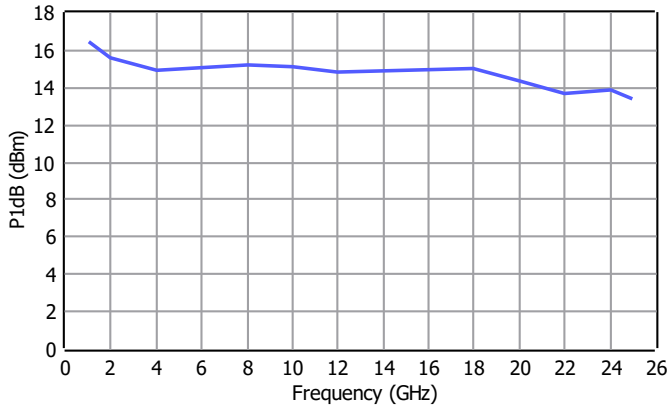

### Pad Description and Mechanical Dimensions

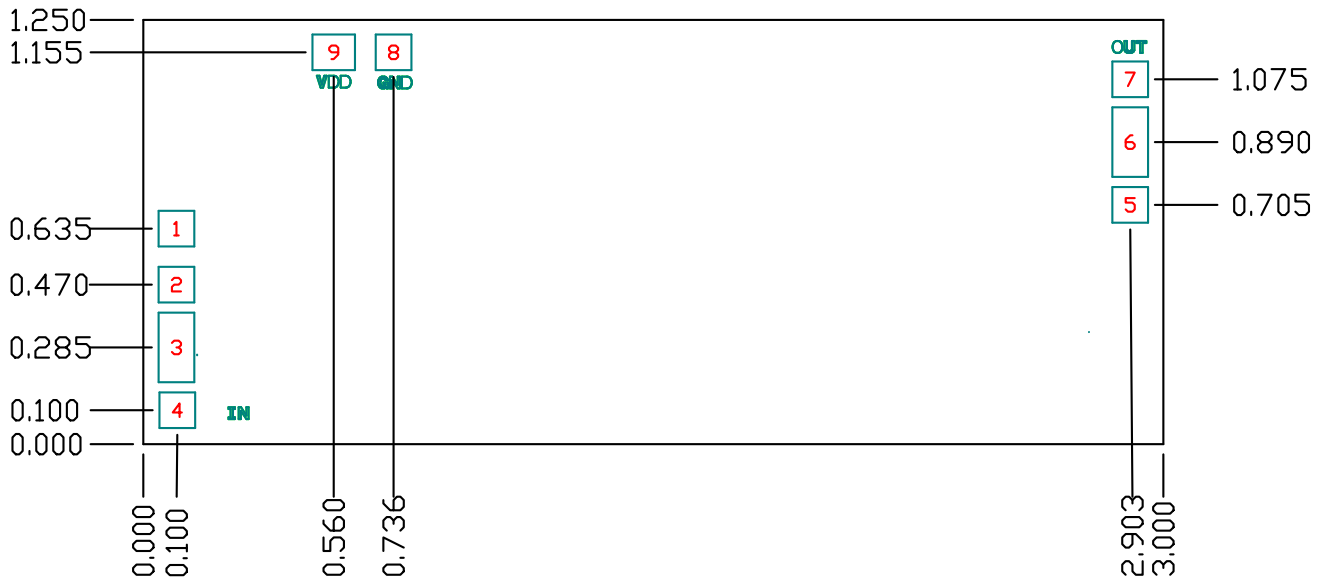

Units: millimeters  
 Thickness: 0.10  
 Die x, y size tolerance: ±0.05  
 Backside of die is ground

| Pad Number    | Pad Name   | Pad Size (mm) | Description  |
|---------------|------------|---------------|--|
| 3             | RF IN      | 0.105x0.205   | RF input pin. AC Coupled.  |
| 6             | RF OUT     | 0.105x0.205   | RF output pin. AC Coupled.   |
| 9             | VDD        | 0.125x0.105   | Vdd bias pin.  |
| 1             | DNC        | 0.105x0.105   | That pin is used for internal purposes. It should be left open/floating. |
| 2, 4, 5, 7, 8 | GND        | 0.105x0.105   | Ground.  |
|               | Die Bottom |               | Ground.  |

## Applications Information

Signal entering from RF IN goes to RF OUT with an amplification.  
Typical application schematic to operate the amplifier is given below.

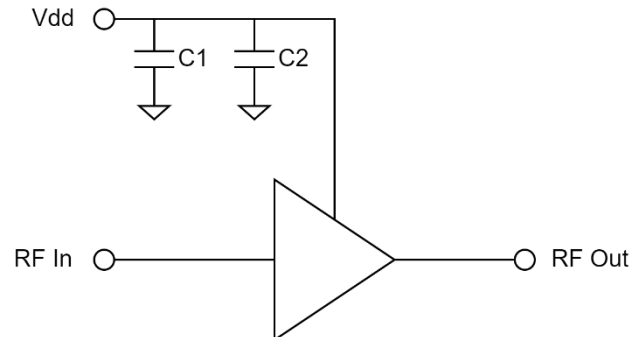

C1 and C2 are used to filter out the ripples and unwanted signals coming from the Vdd supply. Using additional capacitors in parallel to C1 and C2 will improve this filtering. If this filtering is of no concern, then amplifier can be operated without C1 and C2.

Small signal plots are gathered with probe PCB measurements, to generate data shown in this document.

Large signal data and noise figure data are generated with connectorized evaluation PCB measurements. Then the PCB trace and connector transition losses are de-embedded, to generate plots shown in this document.

### Absolute Maximum Ratings

| Parameter            | Value/Range   |
|----------------------|---------------|
| Supply Voltage (Vdd) | TBD           |
| RF Input Power       | TBD           |
| Storage Temperature  | -55 to +125°C |
|                      |               |

Operation of this device outside the parameter ranges given above may cause damage. These conditions should not be applied simultaneously.

## Handling Precautions



Caution!  
ESD-Sensitive Device  
Handle Accordingly

## Contact Information

For the latest specifications, additional product information, support, and sales.

Web: [www.atekmidas.com](http://www.atekmidas.com)

Tel: +90-212-483-71-67

Email: [support@atekmidas.com](mailto:support@atekmidas.com)

## Notice

This document and its contents are property of ATEK MIDAS. ATEK MIDAS has the right to change the document at any time without notice. ATEK MIDAS distributes this document as a service to its customers. ATEK MIDAS supports its customers to help them create market leader products. Customer is responsible from choosing the product and the configuration the product. This document is provided `as is` and does not provide any warranty.

Customer is responsible for the usage of this document, the information provided in the document and the usage of products. ATEK MIDAS shall have no responsibility from the customer products, customer applications and doings of customers.

## Revisions

| Revision No | Revision Date | Revision Reason | Section / Page No |
|-------------|---------------|-----------------|-------------------|
| 1.0         | 10.01.2024    | Initial Release |                   |