

Product Description

ATEK1001 is a pre-selector module covering 485 - 8000 MHz frequency band. Pre-selector consists of an SP8T switch followed by 7 fixed frequency sub-octave band pass filters which are followed by another SP8T switch. 8th path is a bypass path which provides user to bypass the filters.

RF Input and Outputs are internally matched to 50 ohms for ease of use.

Pre-selector provides 43 dBm IIP3 which allows users to realize high dynamic range wideband receiver frontends. Sub-octave filterbank architecture improves overall system IIP2.

Pre-selector is housed in custom milled metal enclosure with USB interface which allows simple control and the bias supply.

Custom package and module options are available upon request.

Product Features

- Frequency Range: 485 - 8000 MHz
- 7 Switchable Band Pass Filters
- Custom milled metal enclosure
- USB interface for control and Vdd supply
- IIP3: 43 dBm
- 36.4x59.9x24.8 mm compact size

Applications

- SDR
- Test Equipment
- Wideband Receivers
- Spectrum Analysis

Functional Block Diagram

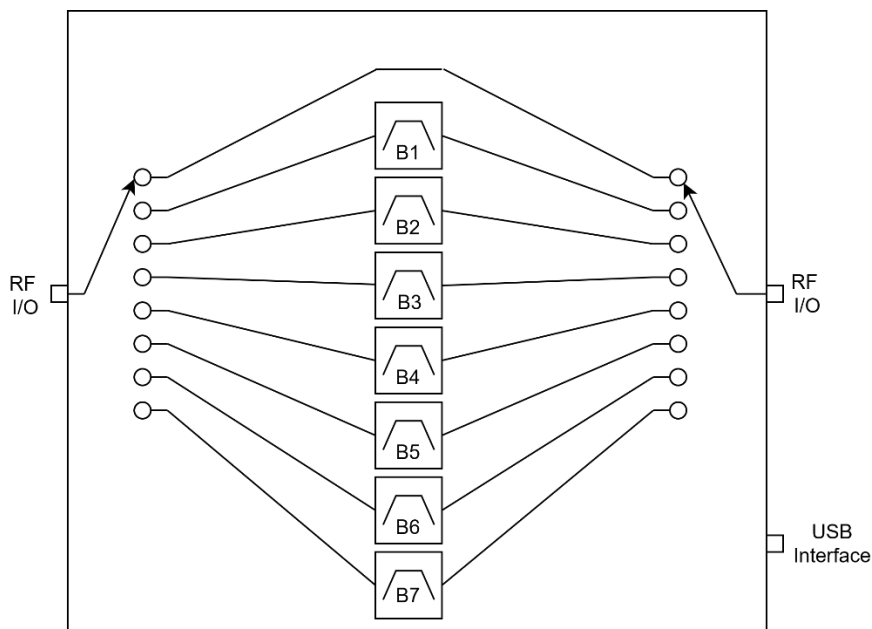

Electrical Specifications

Test conditions unless otherwise noted: T = 25 C.

Parameter		Min	Typ.	Max	Units
Frequency Range		2		8000	MHz
3dB Bandwidth (High Pass 3dB cutoff - Low Pass 3dB cutoff)	Band 1		485 - 810		MHz
	Band 2		670 - 1125		
	Band 3		960 - 1670		
	Band 4		1440 - 2560		
	Band 5		2140 - 3850		
	Band 6		3300 - 5880		
	Band 7		4820 - 8500		
Insertion Loss	Filter Paths		6.5		dB
	Bypass Path		3.5		
Input IP3			43		dBm
Switching Speed			150		nS
DC Supply Current over USB			20		mA
Operating Temperature		-40		85	°C

Typical Performance Plots

Conditions unless otherwise specified: T = 25 C.

S21

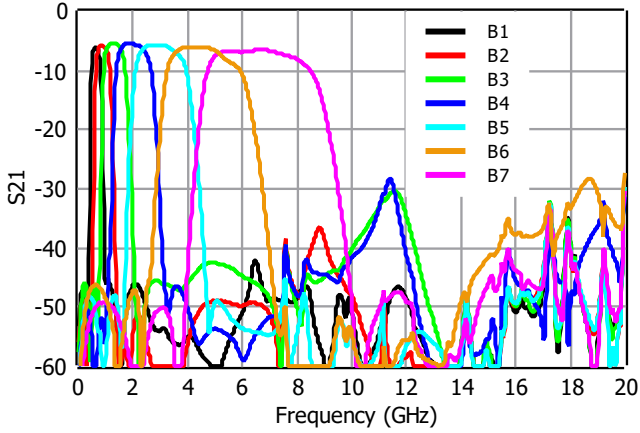

S21

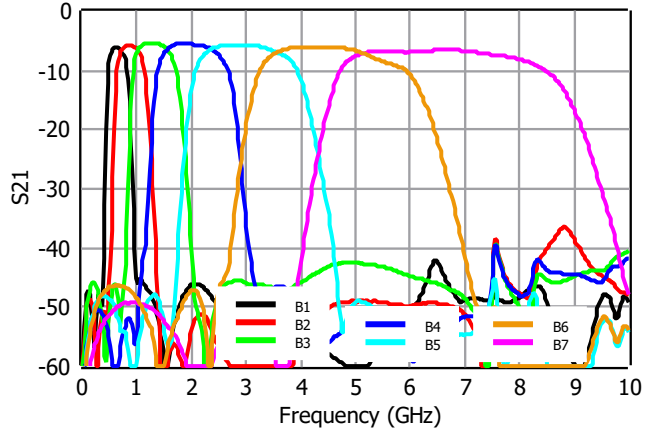

S21, Log Scale

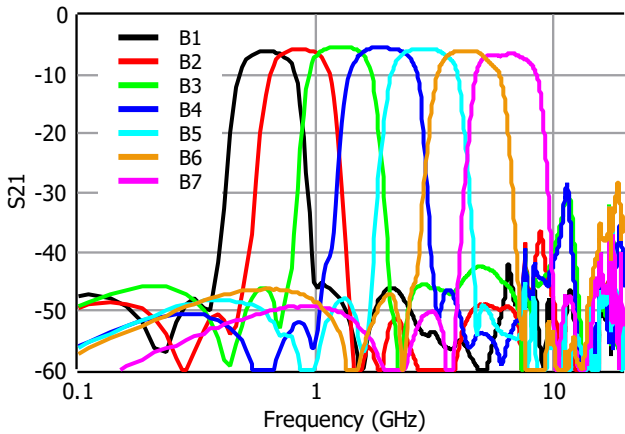

S21, Log Scale

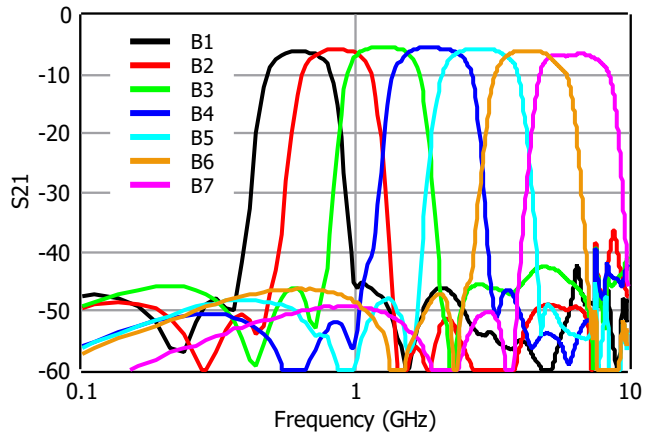

S21

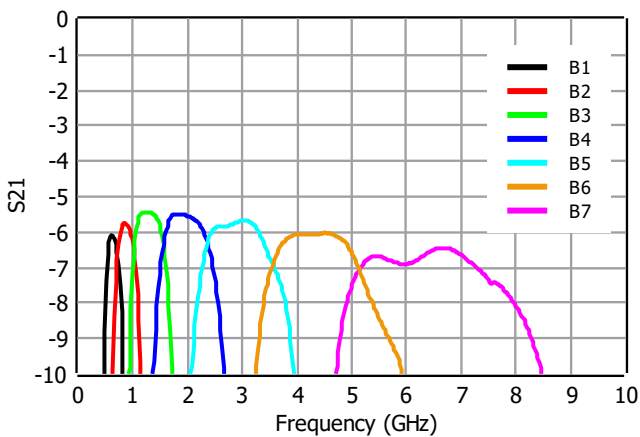

S21, Log Scale

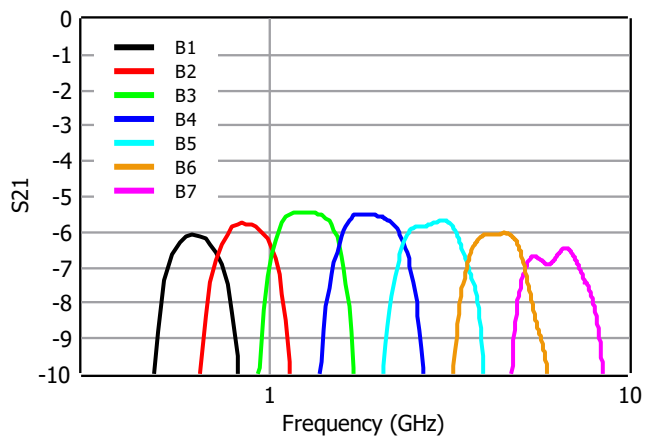

Typical Performance Plots

Conditions unless otherwise specified: T = 25 C.

S11

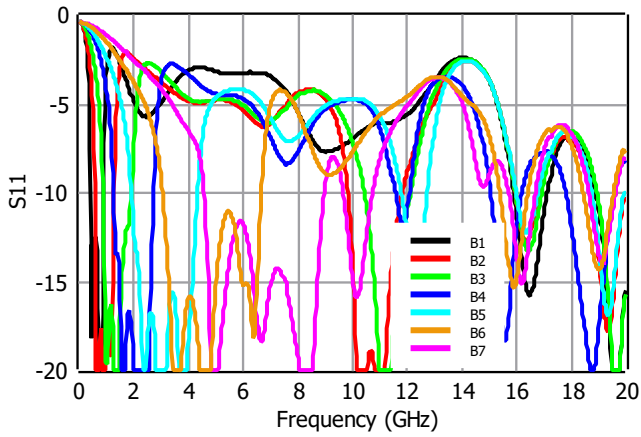

S22

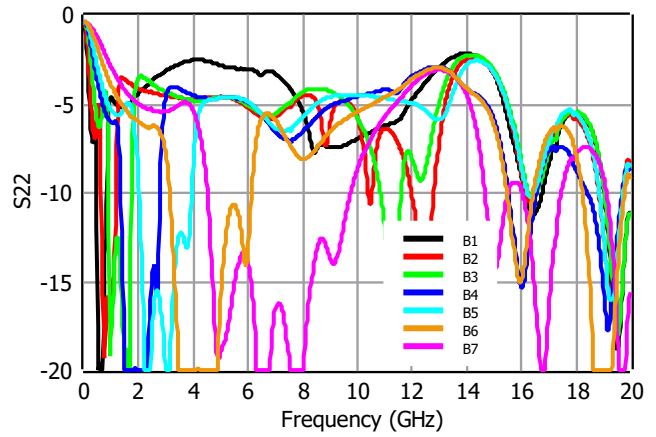

Band1 S21

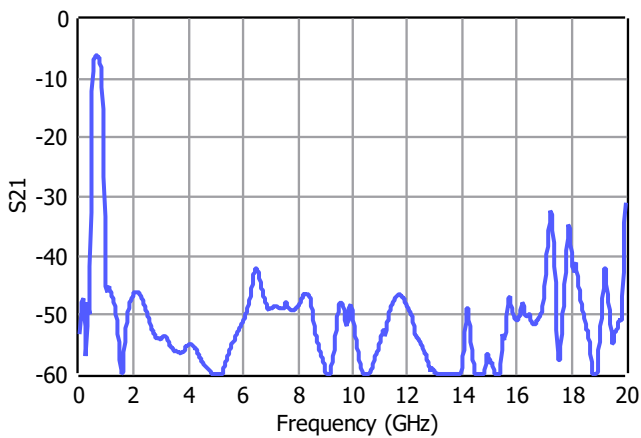

Band1 S11

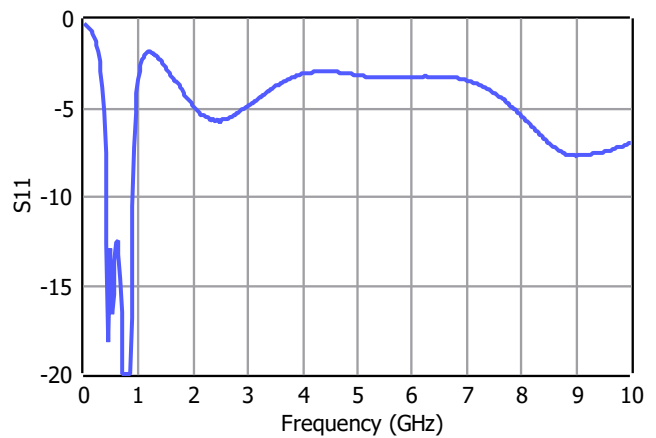

Band2 S21

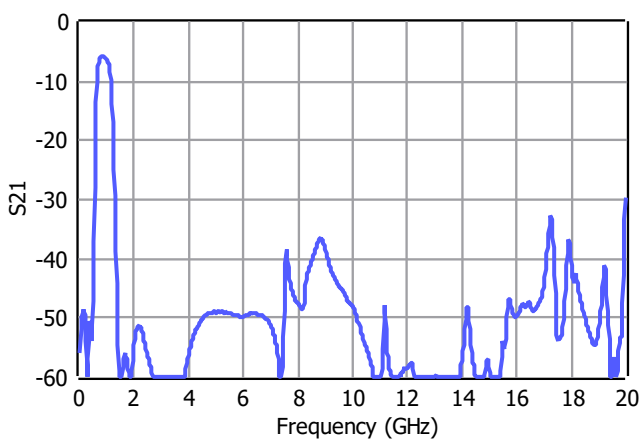

Band2 S11

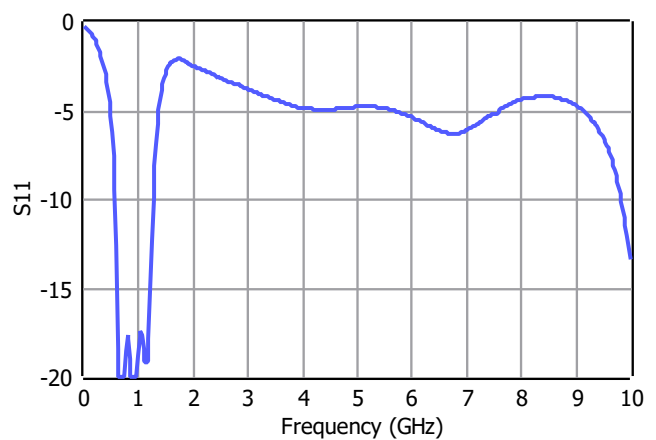

Typical Performance Plots

Conditions unless otherwise specified: T = 25 C.

Band3 S21

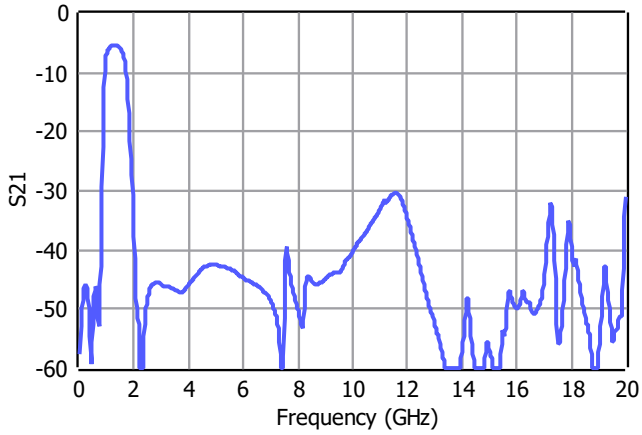

Band3 S11

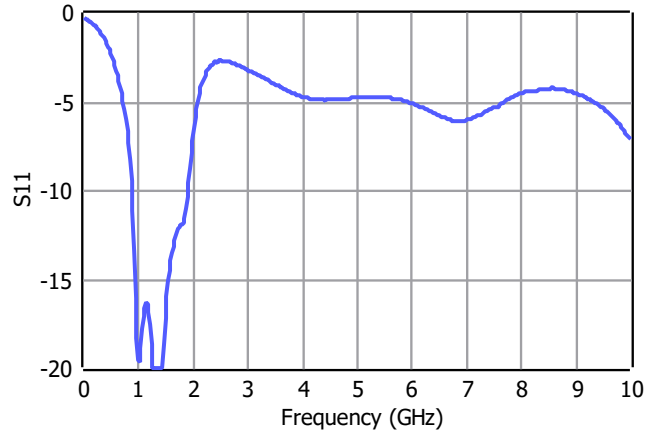

Band4 S21

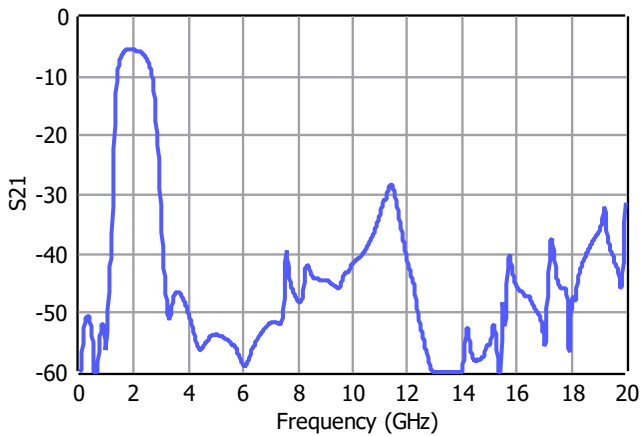

Band4 S11

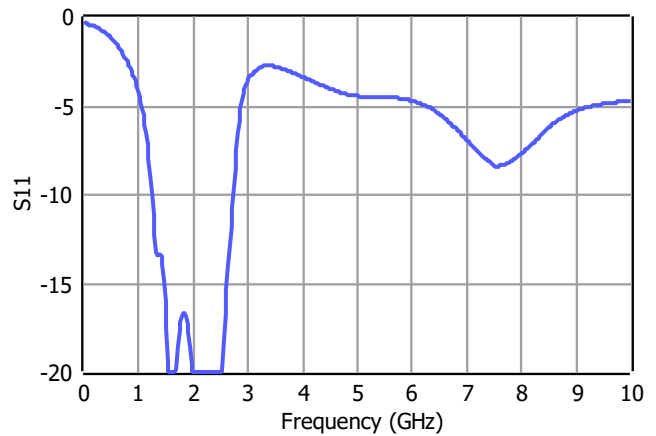

Band5 S21

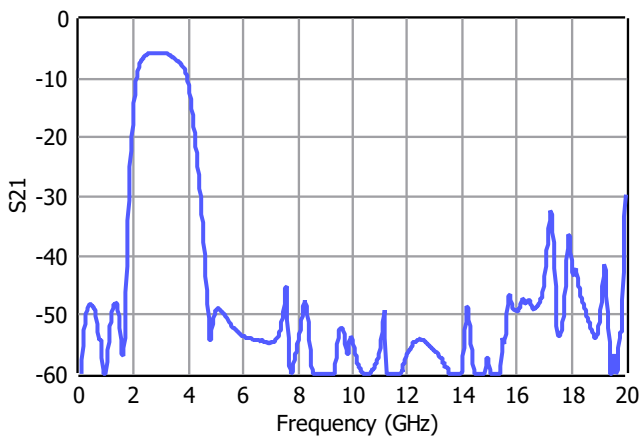

Band5 S11

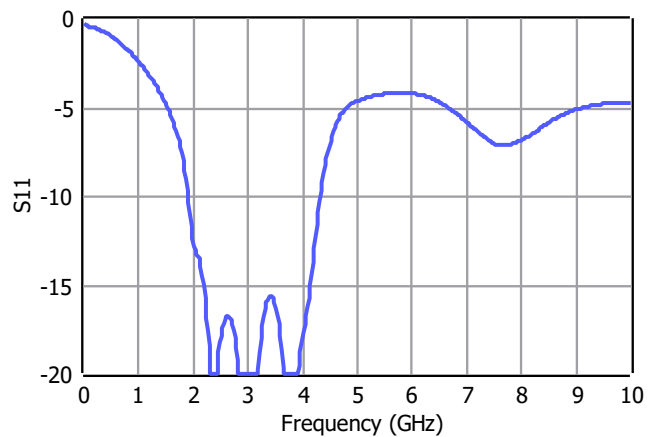

Typical Performance Plots

Conditions unless otherwise specified: T = 25 C.

Band6 S21

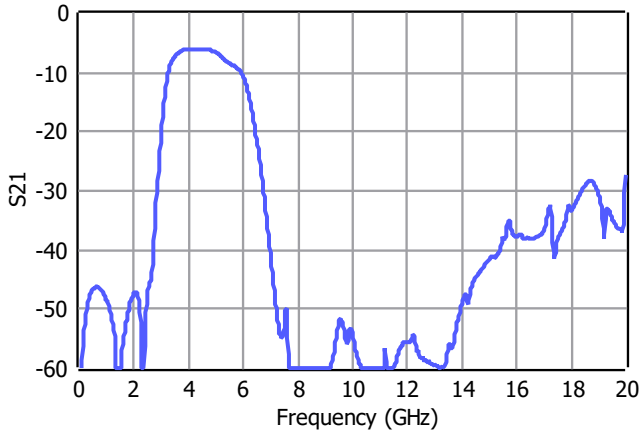

Band6 S11

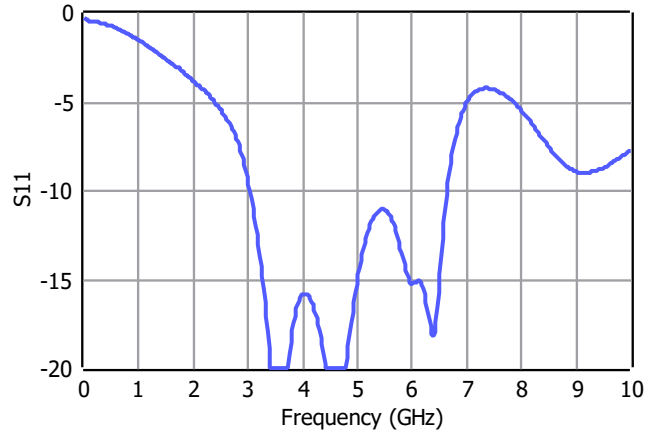

Band7 S21

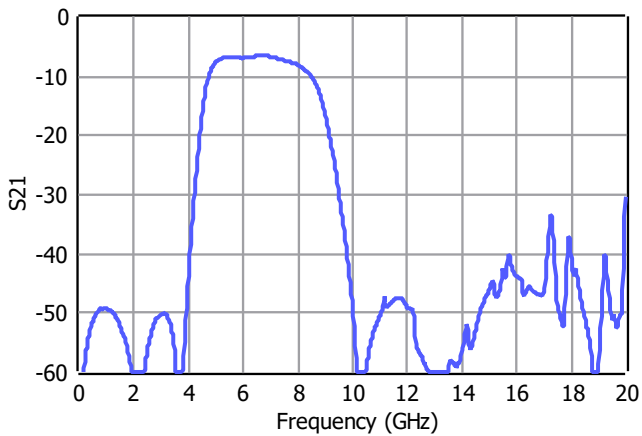

Band7 S11

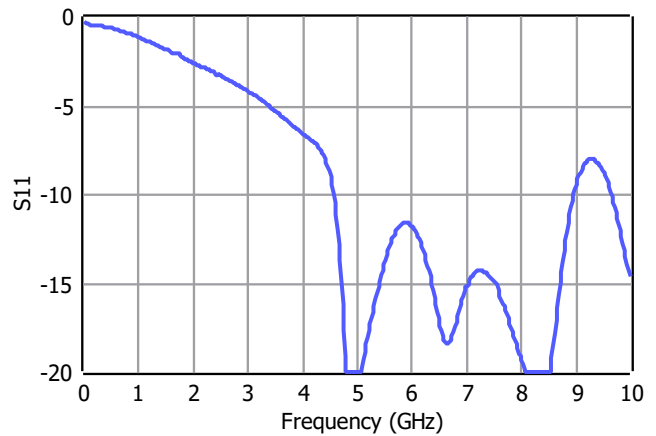

Band1 S21, Log Scale

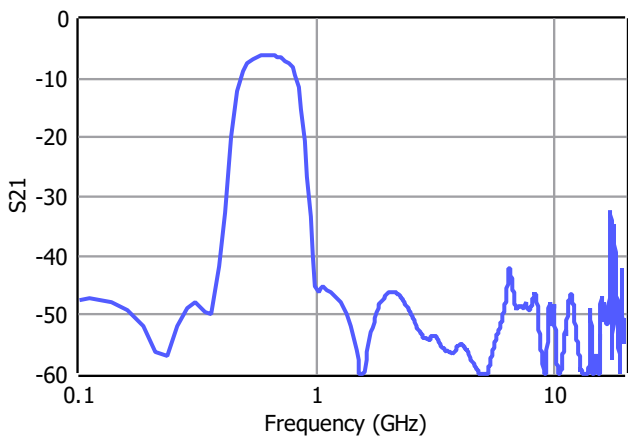

Band2 S21, Log Scale

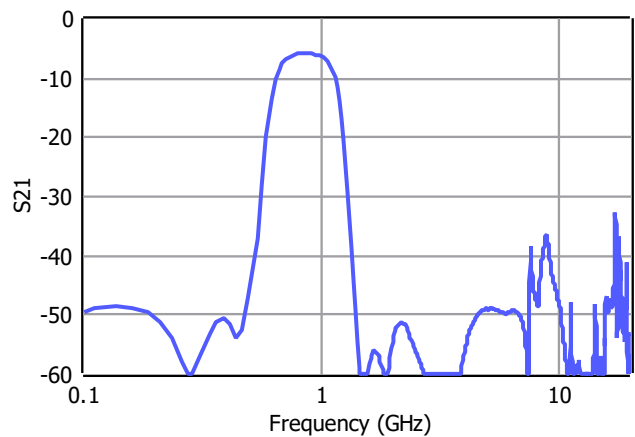

Typical Performance Plots

Conditions unless otherwise specified: T = 25 C.

Band3 S21, Log Scale

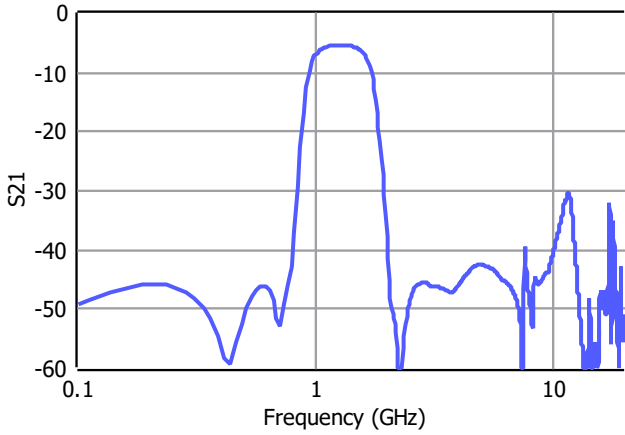

Band4 S21, Log Scale

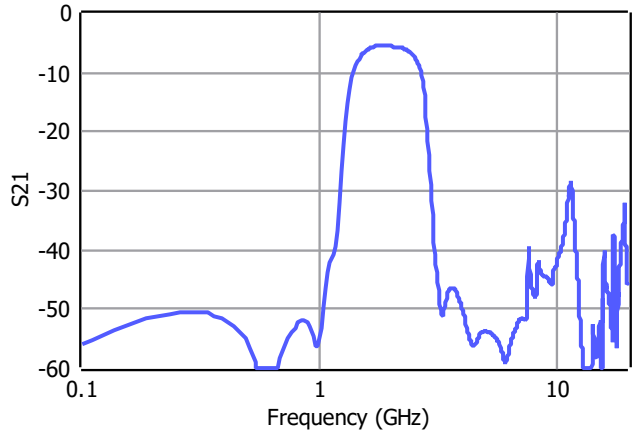

Band5 S21, Log Scale

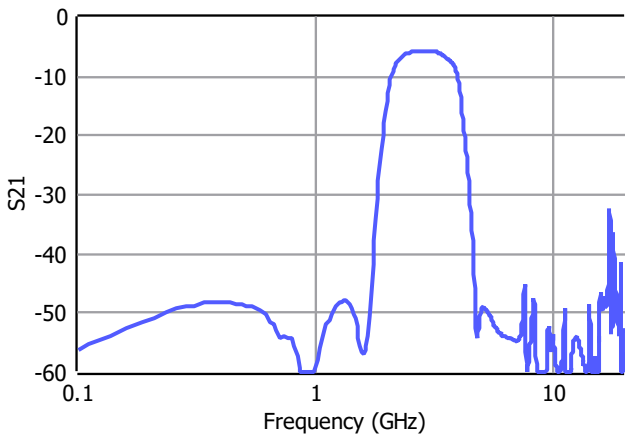

Band6 S21, Log Scale

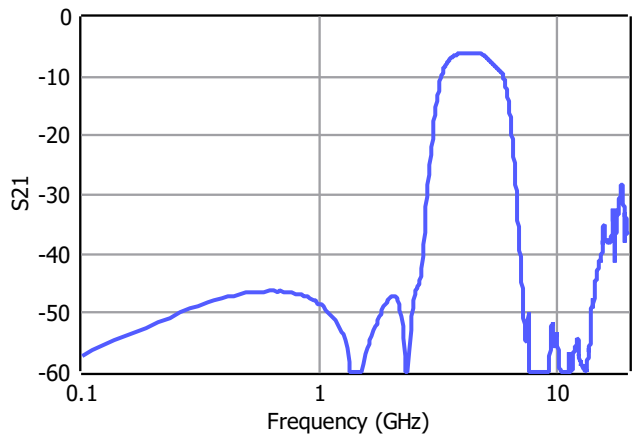

Band7 S21, Log Scale

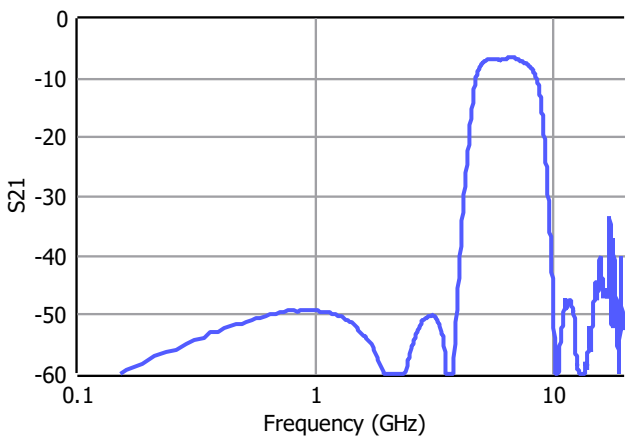

Typical Performance Plots

Test conditions unless otherwise specified: T = 25 C.

Thru Path S21

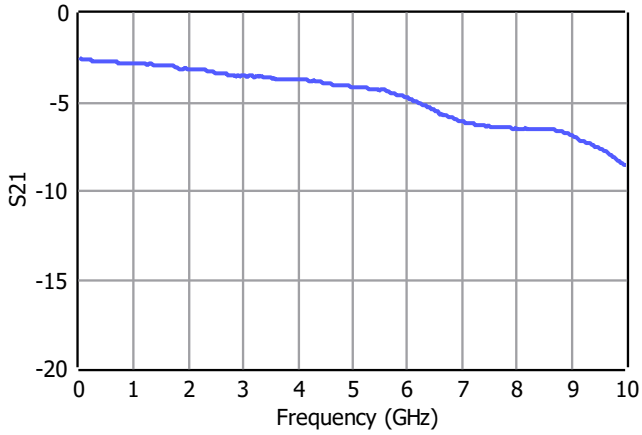

Thru Path S11

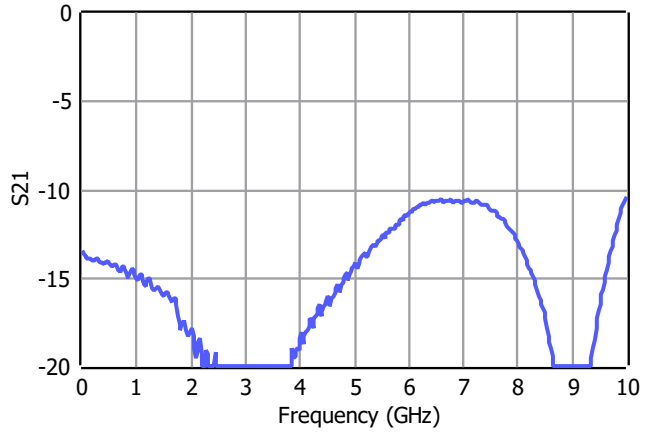

Input IP3 Thru Path

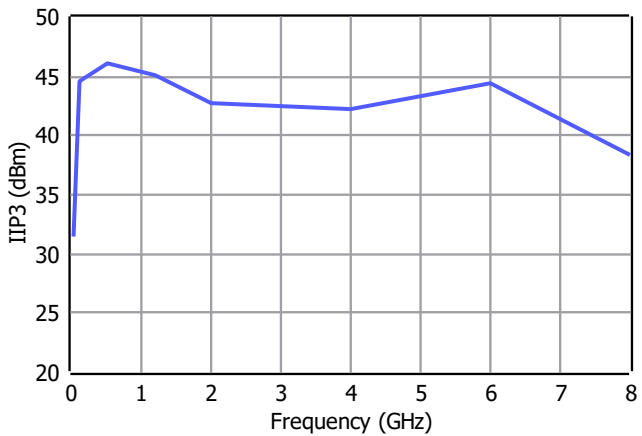

Input IP3 Thru Path, Log Scale

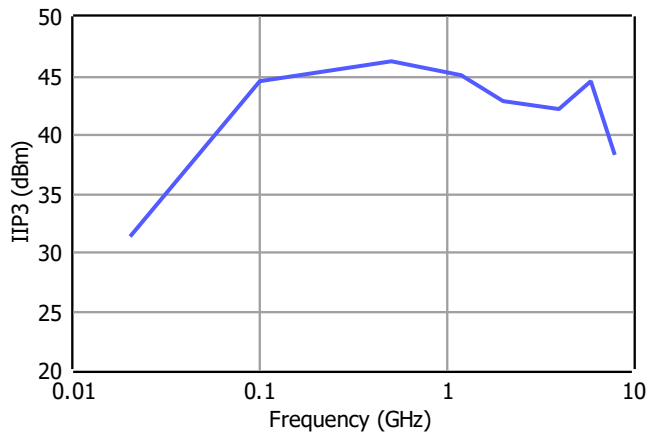

Input IP3, Filter Path

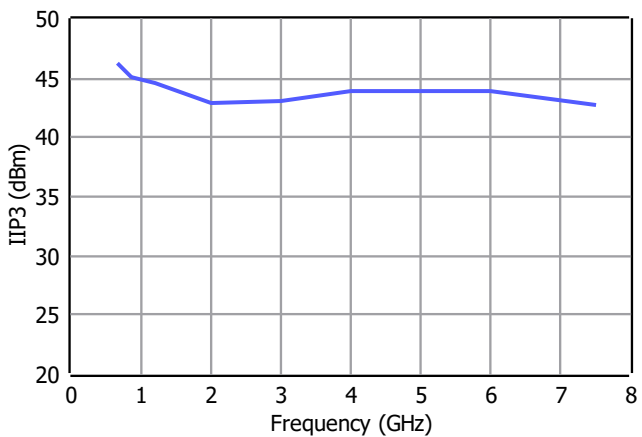

Applications Information

Signal entering from RF I/O goes into 8 selectable paths. 7 of these paths are fixed frequency band pass filters and the 8th path is a bypass path which provides user to bypass the filters.

Typical application schematic to operate the pre-selector is given below.

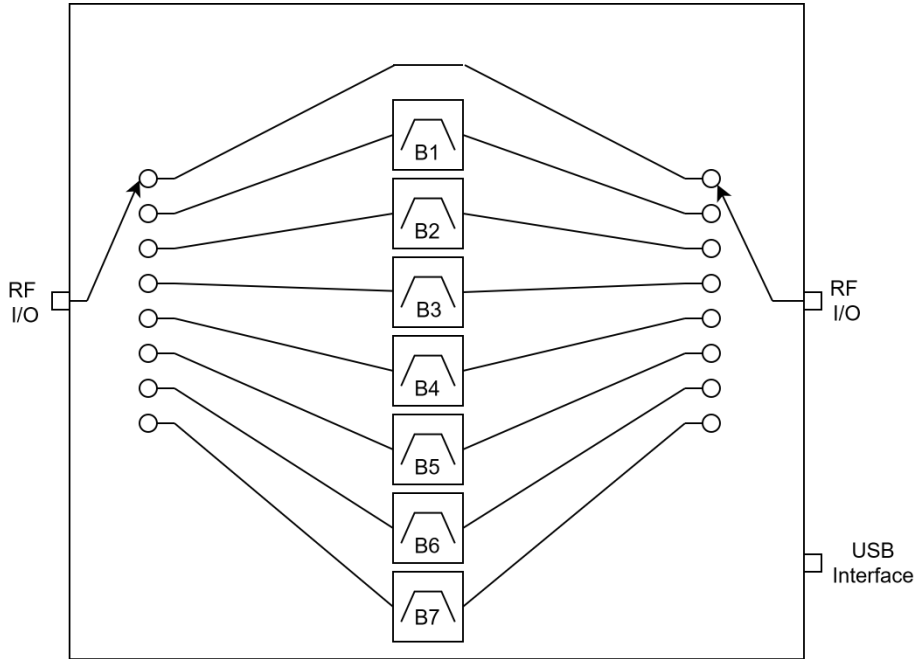

Bias and control requirements for band selection is provided through USB interface. Easy to use GUI is provided for the operator as shown below.

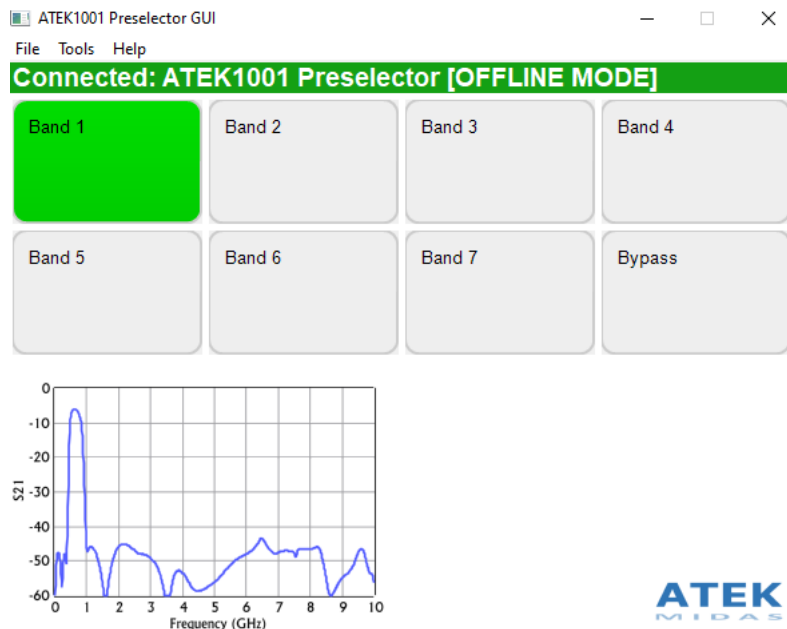

Band selection is done simply by mouse clicking the button of target filter band.

Absolute Maximum Ratings

Parameter	Value/Range
USB interface rails	5.5 V
RF input power	+15 dBm
Storage Temperature	-55 to +125°C

Operation of this device outside the parameter ranges given above may cause damage. These parameters should not be applied simultaneously.

Mechanical and Marking Information

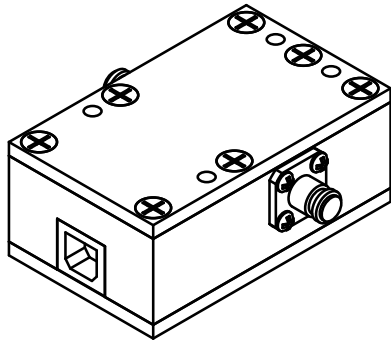

3D View

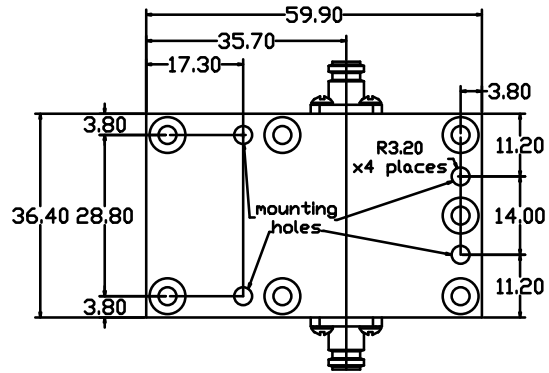

Top View

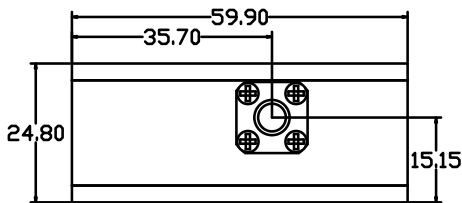

Side View A

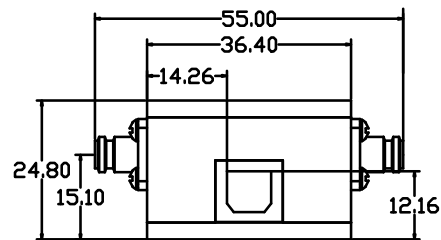

Side View B

All dimensions are in mm.

USB type B- connector for control and power supply.

4 mounting holes with 3.2 mm radius.

2 RF SMA connectors for RF I/O interface.

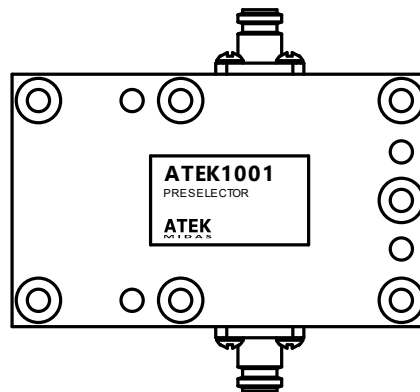

Handling Precautions



Caution!
ESD-Sensitive Device
Handle Accordingly

Contact Information

For the latest specifications, additional product information, support, and sales.

Web: www.atekmidas.com

Tel: +90-212-483-71-67

Email: support@atekmidas.com

Notice

This document and its contents are property of ATEK MIDAS. ATEK MIDAS has the right to change the document at any time without notice. ATEK MIDAS distributes this document as a service to its customers. ATEK MIDAS supports its customers to help them create market leader products. Customer is responsible from choosing the product and the configuration the product. This document is provided `as is` and does not provide any warranty.

Customer is responsible for the usage of this document, the information provided in the document and the usage of products. ATEK MIDAS shall have no responsibility from the customer products, customer applications and doings of customers.

Revisions

Revision No	Revision Date	Revision Reason	Section / Page No
1.0	2021	Initial Release	
1.1	2021	Drawing and Plots Updated	
1.2	24.03.2022	Drawing and Plots Updated	
1.3	25.05.2022	Format and Content Fixed	