



# User Guide

## EVB-ATEK951N4-01

---

Document Code : 023-114101  
Revision No : 02  
Revision Date : 26/07/2023

**Revisions**

Revision No	Revision Date	Revision Reason	Section / Page No
1.0	29.03.2022	Initial Release	
1.1	26.07.2023	Pin Definition Revised	

**INDEX**

<b>1</b>	<b>GENERAL INFORMATION .....</b>	<b>3</b>
<b>2</b>	<b>DESIGN INFORMATION.....</b>	<b>4</b>
<b>2.1</b>	<b>SCHEMATIC.....</b>	<b>4</b>
<b>2.2</b>	<b>BOM .....</b>	<b>4</b>
<b>3</b>	<b>TYPICAL PERFORMANCE PLOTS.....</b>	<b>5</b>

1 GENERAL INFORMATION

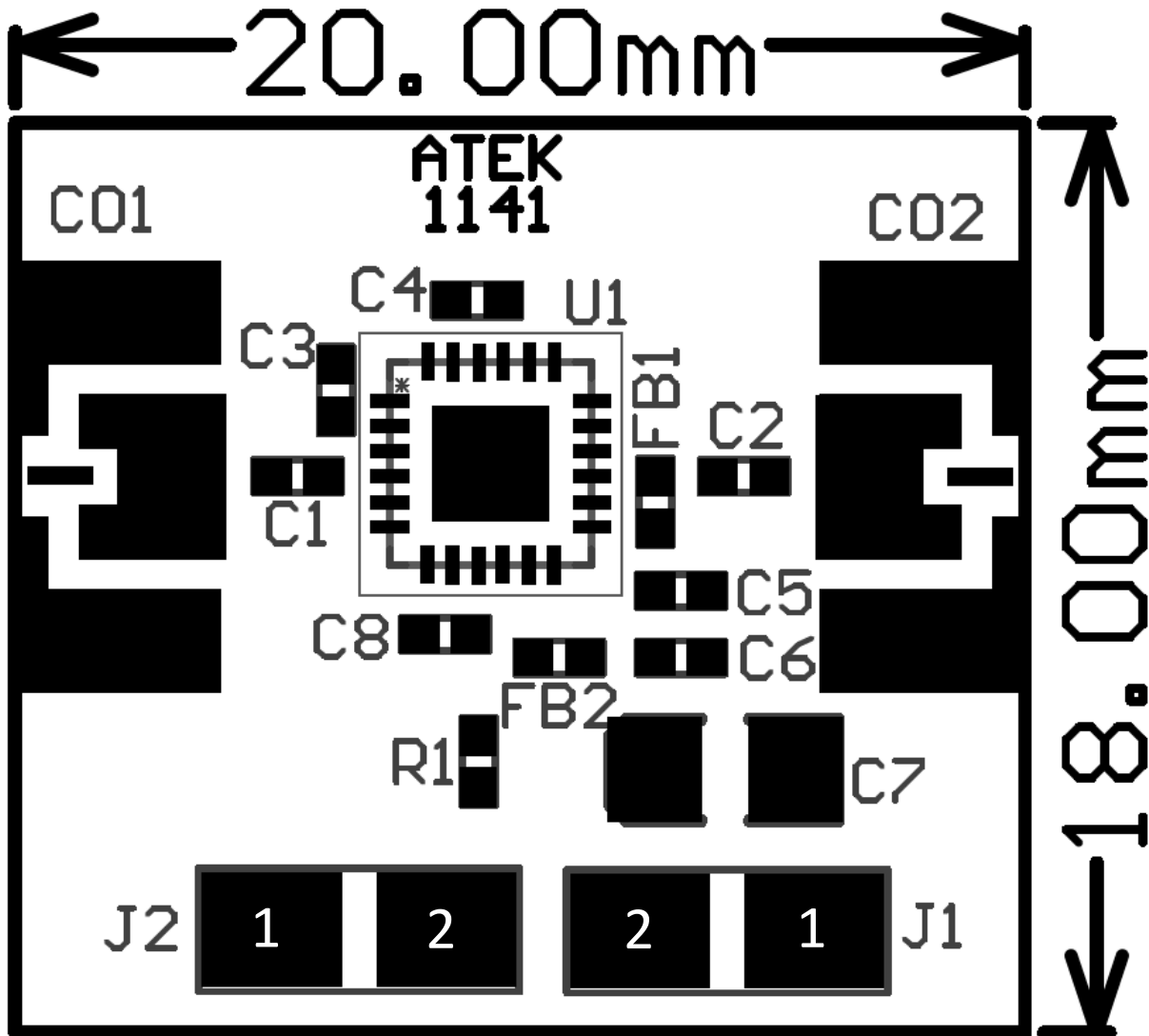

PIN Name	Definition	Comment
CO1	RF IN	SMA Connector
CO2	RF OUT	SMA Connector
J1.1	GND	2.54mm Header
J1.2	VDD	2.54mm Header
J2.2	Control Voltage	2.54mm Header
J2.1	GND	2.54mm Header

Notes:

1. Refer to the datasheet for VDD and Control Voltage details.

2 DESIGN INFORMATION

2.1 SCHEMATIC

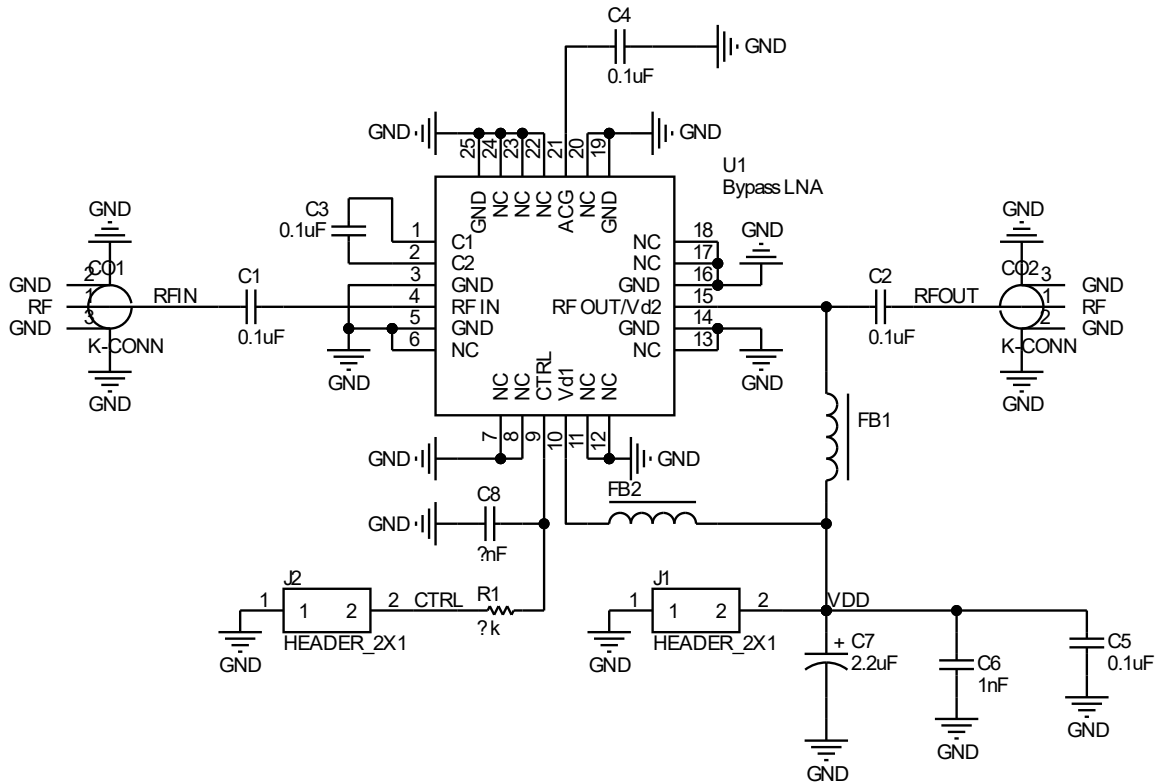

2.2 BOM

Designator	Footprint	Qty	Comment	PN
C1, C2, C3	0402	3	100nF	
C4	0402	1	DNP	
C5	0402	1	100nF	
C6	0402	1	1nF	
C7	CASEA	1	2.2uF	
C8	0402	1	DNP	
CO1, CO2	SMA Connector	2	SMA Connector	
FB1, FB2	0402	2	Ferrite Bead	
J1, J2	2x1 Header	2	2x1 Header	
R1	0402	1	0R	
U1	ATEKQ4424	1	Bypass LNA	ATEK951N4

3 TYPICAL PERFORMANCE PLOTS

Conditions unless otherwise specified:  $V_{dd} = 5V$ ,  $V_{CTRL} = 0/5V$ ,  $T = 25\text{ C}$ , CW. For details, please refer to the datasheet.

Gain Wideband, LNA State

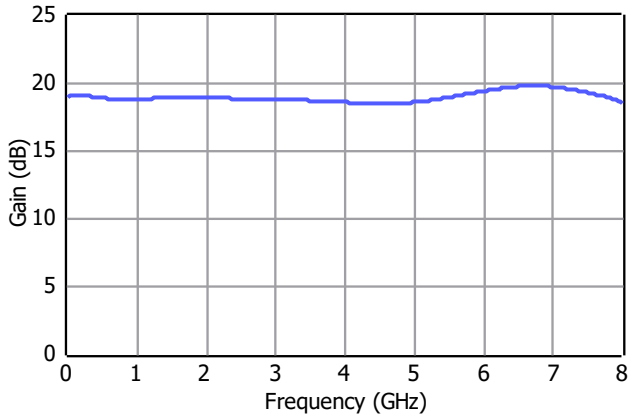

Gain Low Frequency, LNA State

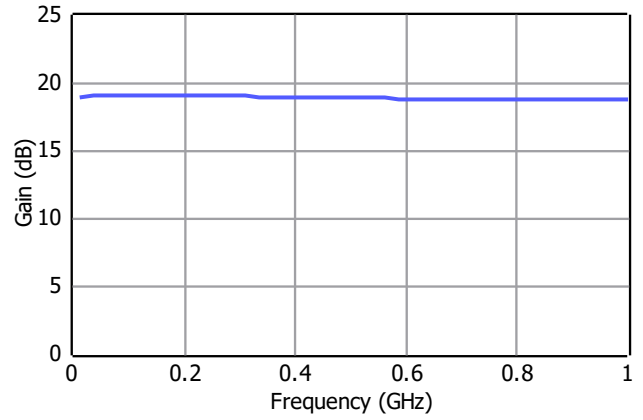

Insertion Loss WideBand, Bypass State

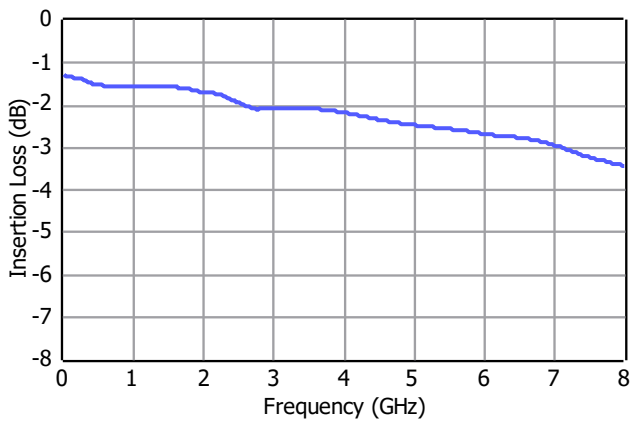

Insertion Loss Low Frequency, Bypass State

