



User Guide

EVB-ATEK264N4-01

Document Code : 023-158201
Revision No : 01
Revision Date : 20/07/2023

Revisions

Revision No	Revision Date	Revision Reason	Section / Page No
1.0	20.07.2023	Initial Release	

INDEX

1	GENERAL INFORMATION	3
2	DESIGN INFORMATION.....	4
2.1	SCHEMATIC.....	4
2.2	BOM	4
3	TYPICAL PERFORMANCE PLOTS.....	5

1 GENERAL INFORMATION

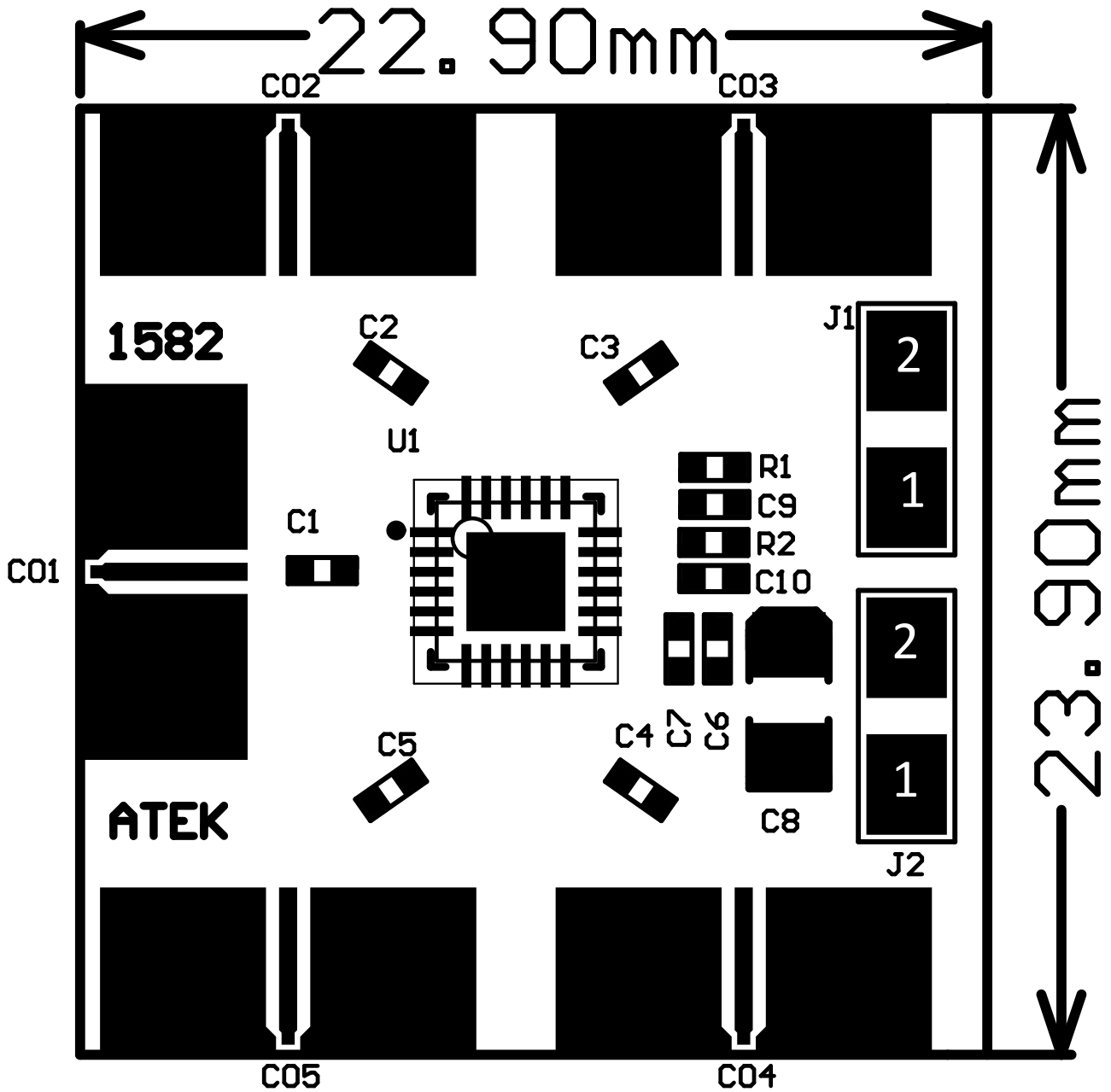

PIN Name	Definition	Comment
CO1	RF IN	K Connector
CO2, CO3, CO4, CO5	RF OUT	K Connector
J1.1	CTRLB	2.54mm Header
J1.2	CTRLA	2.54mm Header
J2.2	VDD	2.54mm Header
J2.1	GND	2.54mm Header

Notes:

1. Refer to the datasheet for VDD and Control Voltage details.

2 DESIGN INFORMATION

2.1 SCHEMATIC

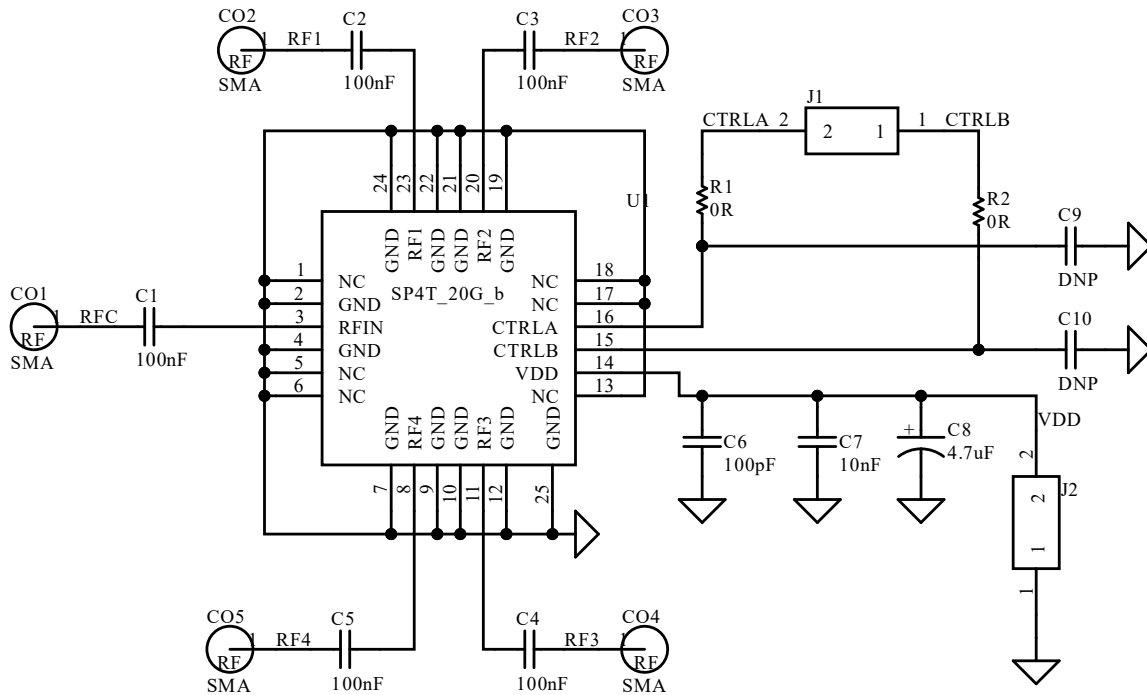

2.2 BOM

Designator	Footprint	Qty	Comment	PN
C1, C2, C3, C4, C5	0402	5	100nF	
C6	0402	1	100pF	
C7	0402	1	10nF	
C8	CASEA	1	4.7uF	
C9, C10	0402	2	DNP	
CO1, CO2, CO3, CO4, CO5	K Connector	5	K Connector	ATEK9292
J1, J2	2x1 Header	2	2x1 Header	
R1, R2	0402	2	0R	
U1	ATEKQ4424	1	SP4T	ATEK264N4

3 TYPICAL PERFORMANCE PLOTS

Conditions unless otherwise specified: $V_{CTRL} = 0 / -5$ V, $T = 25$ C, CW. For details, please refer to the datasheet.

Insertion Loss

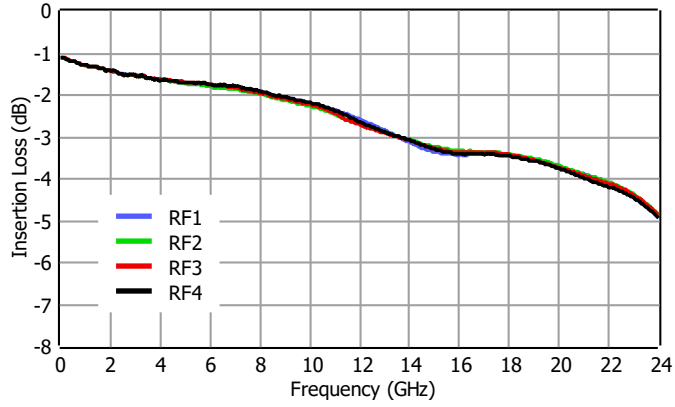

Return Loss

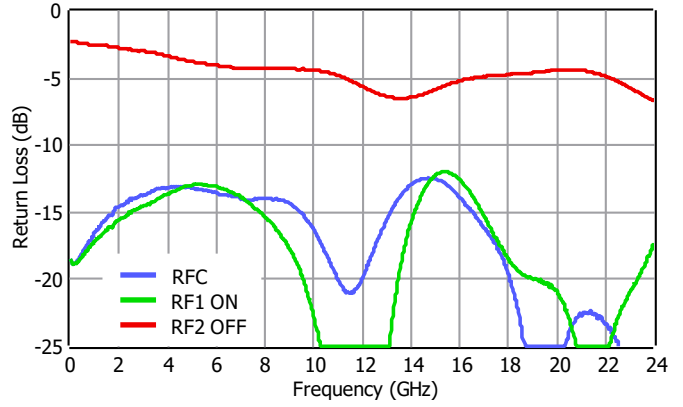

Isolation

